

## 1600EP SERIES

### INSTRUCTION MANUAL

SINGLE PHASE - 3.6-RoHS/3.6/6/8/10/14/18/22 kVA

Part # 55288-003  
June 2009

Manufactured in the USA





---

# 1600EP SERIES

---

INSTRUCTION MANUAL  
SINGLE PHASE - 3.6-RoHS/3.6/6/8/10/14/18/22 kVA

Part # 55288-003  
June 2009



## Product Use and Warranty Restrictions

The Toshiba products listed in this document are intended for usage in general electronics applications (computer, personal equipment, office equipment, measuring equipment, industrial robotics, domestic appliances, etc.). These Toshiba products are neither intended nor warranted for usage in equipment that requires extraordinarily high quality and/or reliability or where a malfunction or failure may cause loss of human life or bodily injury (Unintended Usage). Unintended Usage include atomic energy control instruments, airplane or spaceship instruments, transportation instruments, traffic signal instruments, combustion control instruments, surgical operating room or life-support equipment, all types of safety devices, etc.. Unintended Usage of Toshiba products listed in this document shall be made at the customer's own risk.

### NOTICE

**PLEASE INFORM TOSHIBA INTERNATIONAL CORPORATION OR AUTHORIZED REPRESENTATIVE IN CASE OF INCONSISTENCIES, OMISSIONS, OR QUESTIONS.**

The instructions contained in this manual are not intended to cover all of the details or variations in equipment, or to provide for every possible contingency concerning installation, operation, or maintenance. Should further information be required or if problems arise which are not covered sufficiently, contact your Toshiba sales office.

The contents of this instruction manual shall not become a part of or modify any prior or existing agreement, commitment, or relationship. The sales contract contains the entire obligation of Toshiba International Corporation UPS Division. The warranty contained in the contract between the parties is the sole warranty of Toshiba International Corporation UPS Division and any statements contained herein DO NOT create new warranties or modify the existing warranty.

Any electrical or mechanical modifications to this equipment without prior written consent of Toshiba International Corporation will void all warranties and may void the UL/CUL listing. Unauthorized modifications can also result in personal injury, loss of life, or destruction of the equipment.

### QUALIFIED PERSONNEL ONLY

Qualified Personnel are those that have the skills and knowledge relating to the construction, installation, operation, and maintenance of the electrical equipment and has received safety training on the hazards involved (Refer to the latest edition of NFPA 70E for additional safety requirements).

**UNINTERRUPTIBLE POWER SYSTEM (UPS)**

Please complete the following information and retain for your records.

Unless otherwise specified, the warranty period for the UPS or UPS part is 36 months from the shipment date (see Toshiba International Corporation bill of lading).

Unless otherwise specified, the warranty period for a UPS battery is 24 months from the shipment date (see Toshiba International Corporation bill of lading).

JOB NUMBER \_\_\_\_\_

MODEL NUMBER \_\_\_\_\_

SERIAL NUMBER \_\_\_\_\_

APPLICATION \_\_\_\_\_

SHIPMENT DATE \_\_\_\_\_

INSTALLATION DATE \_\_\_\_\_

INSPECTED BY \_\_\_\_\_

## Purpose

This manual provides information on how to safely install your Toshiba International Corporation power electronics product. This manual includes a section of general safety instructions that describes the warning labels and symbols that are used throughout the manual. Read the manual completely before installing, operating, or performing maintenance on this equipment.

This manual and the accompanying drawings should be considered a permanent part of the equipment and should be readily available for reference and review. Dimensions shown in the manual are in metric and/or the English customary equivalent.

Toshiba International Corporation reserves the right, without prior notice, to update information, make product changes, or discontinue any product or service identified in this publication.

Toshiba is a registered trademark of the Toshiba Corporation. All other product or trade references appearing in this manual are registered trademarks of their respective owners.

Toshiba International Corporation shall not be liable for direct, indirect, special, or consequential damages resulting from the use of the information contained within this manual.

This manual is copyrighted. No part of this manual may be photocopied or reproduced in any form without the prior written consent of Toshiba International Corporation.

© Copyright 2009 Toshiba International Corporation  
All rights reserved.  
Printed in the U.S.A.

## Toshiba Customer Support Center

Contact the Toshiba Customer Support Center for assistance with application information or for any problems that you may experience with your Uninterruptible Power System (UPS).

### **Toshiba Customer Support Center**

8 a.m. to 5 p.m. (CST) - Monday through Friday  
USA Toll Free (877) 867-8773  
Tel (713) 466-0277  
Fax (713) 466-8773

You may also contact Toshiba by writing to:

### **Toshiba International Corporation**

13131 West Little York Road  
Houston, Texas 77041-9990  
Attn: UPS Product Manager

For further information on Toshiba products and services, please visit our website at:

**[www.toshiba.com/ind](http://www.toshiba.com/ind)**

## Table of Contents

<b>General Safety Instructions</b> .....	<b>1</b>
Symbols.....	1
Signal Words .....	2
<b>IMPORTANT SAFETY INSTRUCTIONS</b> .....	<b>3</b>
QUALIFIED PERSONNEL ONLY .....	3
<b>INSTRUCTIONS IMPORTANTES CONCERNANT LA SÉCURITÉ</b> .....	<b>4</b>
<b>Product Description</b> .....	<b>5</b>
Application and Use.....	5
Output Rating.....	5
Power Backup.....	5
Power Conditioning.....	5
<b>Inspection/Storage/Disposal</b> .....	<b>6</b>
Inspection .....	6
Storage .....	6
Disposal.....	6
<b>Installation Precautions</b> .....	<b>7</b>
<b>Conductor Routing and Grounding</b> .....	<b>7</b>
<b>Operating Precautions</b> .....	<b>8</b>
<b>Equipment Warning Labels</b> .....	<b>9</b>
<b>UPS Connections</b> .....	<b>11</b>
<b>Communication Interfaces</b> .....	<b>12</b>
UPS Stop Signal Operation .....	13
RS-232C .....	14
RemotEye II Network Card.....	14
<b>UPS Specifications</b> .....	<b>15</b>
<b>Operating the UPS</b> .....	<b>21</b>
Battery Backup Time and Discharge Process .....	21
Starting the UPS.....	22
Battery Recharging .....	23
<b>Online Mode</b> .....	<b>24</b>
Online Mode (Run operation) .....	24
Static-Bypass Mode (Stop operation).....	24
Battery Backup Mode (On batteries) .....	25
EPO (Emergency Power Off) Function.....	25
Audible Alarm Functions .....	26

<b>Display and Keys</b> .....	<b>27</b>
Front Panel Layout .....	27
Liquid Crystal Display (LCD) Functions .....	27
Operating Keys .....	28
Light Emitting Diodes (LED) .....	28
<b>Display Screens</b> .....	<b>29</b>
Screen Arrangement.....	29
System Overview Screens.....	29
UPS Start-Up Screens Sequence.....	29
Data Display Screens .....	31
Special Display Screens .....	32
Data Setting Screens.....	33
System Warning Messages .....	39
System Fault Messages .....	40
Status Change Indications.....	41
<b>UPS Protection System</b> .....	<b>42</b>
System Protection Features .....	42
System Protection Functions .....	42
<b>Preventive Maintenance/Parts Replacement</b> .....	<b>44</b>
Preventive Maintenance .....	44
Parts Replacement .....	44
<b>Optional Receptacle Panel Installation Instructions</b> .....	<b>45</b>
<b>Optional MB (Maintenance Bypass) Units</b> .....	<b>46</b>
<b>External Layouts/Dimensions/Shipping Weights</b> .....	<b>48</b>
Dimensional Data .....	48
Electrical Conduit Knock-out Data.....	48
Unit and Shipping Weights .....	48
<b>Index</b> .....	<b>51</b>

## General Safety Instructions

DO NOT attempt to transport, install, operate, maintain or dispose of this equipment until you have read and understood all of the product safety information provided in this manual.

### Symbols

The symbols listed below are used throughout this manual. When symbols are used in this manual they will include important safety information that must be carefully followed.



**Safety Alert Symbol** indicates that a potential personal injury hazard exists.



**Prohibited Symbol** indicates **DO NOT** take action.



**Mandatory Symbol** indicates that the following instruction is required.



**Ground Symbol** indicates the location of the equipment grounding conductor.



**Electrical - Voltage & Shock Hazard Symbol** indicates parts inside may cause electric shock.



**Explosion Hazard Symbol** indicates parts may explode.

## Signal Words

The signal words listed below are used throughout this manual. When the words DANGER, WARNING, CAUTION and ATTENTION are used in this manual they will include important safety information that must be carefully followed.



### **DANGER**

The word **DANGER** in capital letters preceded by the safety alert symbol indicates that an **imminently hazardous** situation exists, if not avoided, **will result in loss of life or serious injury to personnel.**



### **WARNING**

The word **WARNING** in capital letters preceded by the safety alert symbol indicates that a **potentially hazardous** situation exists, if not avoided, **may result in loss of life or serious injury to personnel.**



### **CAUTION**

The word **CAUTION** in capital letters preceded by the safety alert symbol indicates that a **potentially hazardous** situation exists, if not avoided, **may result in minor or moderate injury.**

### **CAUTION**

The word **CAUTION** in capital letters without the safety alert symbol indicates a **potentially hazardous** situation exists, if not avoided, **may result in equipment and property damage.**

### **ATTENTION**

The word **ATTENTION** in capital letters without the safety alert symbol indicates a **potentially hazardous** situation exists, if not avoided, **may result in equipment and property damage.**

## IMPORTANT SAFETY INSTRUCTIONS

This manual contains important instructions that should be followed during the installation and maintenance of the UPS and its batteries.

Hardwire-type UPS units are not equipped with an over-current protection device nor an output disconnect for the AC output. A circuit breaker should be provided by the user between the UPS output and the load input. This device should be rated as follows:

240VAC RATING	3.6-RoHS kVA	3.6 kVA	6 kVA	8 kVA	10 kVA	14 kVA	18 kVA	22 kVA
	20 A	20 A	30 A	40 A	60 A	80 A	125 A	150 A

The nominal battery voltages for these models are as follows:

BATTERY VOLTAGE	3.6-RoHS kVA	3.6 kVA	6 kVA	8 kVA	10 kVA	14 kVA	18 kVA	22 kVA
	144 Vdc	216 Vdc	216 Vdc	288 Vdc	288 Vdc	288 Vdc	288 Vdc	288 Vdc

Servicing of the batteries should only be performed by a qualified factory authorized representative who is knowledgeable of batteries and the required precautions. Keep unauthorized personnel away from batteries. To arrange for battery replacement, contact your nearest factory authorized service center.

1. Turn off, lockout, and tagout all equipment before connecting the power wiring to the equipment or when performing maintenance.
2. Hardwire type UPS units are not equipped with an over-current protection device, nor do they have an output disconnect for the AC output. Therefore, a user-installed circuit breaker should be provided between the UPS output and the load input.
3. The maximum ambient operating temperature is 104 °F (40 °C).
4. Battery servicing should be performed by qualified Toshiba representative only.
5. Unauthorized personnel should not service batteries.
6. Contact your Toshiba authorized service center for battery replacement.

### QUALIFIED PERSONNEL ONLY

**Qualified personnel** is one that has the skills and knowledge relating to the construction, installation, operation, and maintenance of the electrical equipment and has received safety training on the hazards involved (Refer to the latest edition of NFPA 70E for additional safety requirements).

#### Qualified personnel shall:

1. Have read the entire operation manual.
2. Be trained and authorized to safely energize, de-energize, ground, lockout and tag circuits and equipment, and clear faults in accordance with established safety practices.
3. Be trained in the proper care and use of protective equipment such as safety shoes, rubber gloves, hard hats, safety glasses, face shields, flash clothing, etc., in accordance with established safety practices.
4. Be trained in rendering first aid.
5. Be knowledgeable of batteries and the required handling and maintenance precautions.

**For further information on workplace safety visit [www.osha.gov](http://www.osha.gov).**



**CAUTION**

Misuse of this equipment may result in human injury and equipment damage. In no event will Toshiba Corporation be responsible or liable for either indirect or consequential damage or injury that may result from the misuse of this equipment.



**CAUTION**



DO NOT dispose of the battery module in a fire. The batteries inside may explode.



**CAUTION**

DO NOT open or mutilate the batteries. Released electrolyte is harmful to the eyes and skin and could also be toxic.

To be performed by **Qualified Personnel Only**:

1. Verify that the UPS is off and that the power cord is disconnected from the power source.
2. Remove watches, rings or other metal objects.
3. Use tools with insulated handles to prevent inadvertent shorts.
4. Wear rubber gloves and boots.
5. DO NOT place tools or any metal parts on top of batteries.
6. Determine if the battery is inadvertently grounded. If inadvertently grounded, remove source of ground.



**WARNING**

**Contact with any part of a grounded battery can result in electrical shock.**

The likelihood of shock will be reduced if such grounds are removed prior to installation or maintenance.

## INSTRUCTIONS IMPORTANTES CONCERNANT LA SÉCURITÉ

### CONSERVER CES INSTRUCTIONS

Cette notice contient des instructions importantes concernant la sécurité.



**ATTENTION**

Une batterie peut présenter un risque de choc électrique, de brûlure par transfert d'énergie.



**ATTENTION**

L'élimination des batteries est réglementée. Consulter les codes locaux à cet effet.

## Product Description

An uninterruptible power system is a system that is installed between the commercial power and the load equipment. The UPS provides steady AC output power during commercial power short-term blackouts or brownouts. This power is provided for a long enough time so that the load can be shut down in an orderly fashion. This prevents loss of data and possible damage to both hardware and software.

During normal operation, the UPS uses commercial AC power. It absorbs all of the high voltage spikes and transients caused by switching and faults, and all of the common-mode and normal mode noise which is associated with commercial AC power. The UPS converts it all to flat DC power. From this power, the UPS charges its batteries and generates its own extremely high quality AC waveform output. The result of this process is maximum power conditioning and regulation.

If the AC power supplied to the UPS drops below a specified voltage level, the unit's batteries automatically begin supplying power instead of receiving it. This insures that the loads connected to the UPS continue to receive power with no interruption. When AC input power becomes available again, operation returns to normal. The unit's batteries begin to recharge so they will be ready for the next power interruption.

## Application and Use

Toshiba 1600EP Series of on-line uninterruptible power system (UPS) provides continuous computer-grade AC power in a compact, high performance, and energy efficient unit. The UPS unit assures safe and reliable operation of critical office equipment. This can range from word processors and personal computers to mini-computers and local area networks. All units feature an audible alarm which sounds if the battery voltage drops below a specified minimum during use. This is an additional aid to help in retaining the valuable office data banks. All units allow for computer interfacing.

## Output Rating

Toshiba 1600EP Series (208/240V) offers UPS models with the following capacities:

MODEL	Output Capacity @ 240 V	Output kW @ .85PF 240 V
UE3G2L036C61TC3*	3.6 kVA	3.1 kW
UE3G2L036C61T	3.6 kVA	3.1 kW
UE3G2L060C61T	6 kVA	5.1 kW
UE3G2L080C61T	8 kVA	6.8 kW
UE3G2L100C61T	10 kVA	8.5 kW
UE3G2L140C61T	14 kVA	11.9 kW
UE3G2L180C61T	18 kVA	15.3 kW
UE3G2L220C61T	22 kVA	18.7 kW

\* UE3G2L036C61TC3 is RoHS compliant with the batteries being exempt from the directive.

## Power Backup

When an electrical power failure occurs, the UPS's internal batteries automatically supply back-up power to the load without interruption. For example, when used to support a computer, the UPS back-up assures enough additional time to complete the activity and store the data. This allows an orderly shutdown after a power failure has occurred.

## Power Conditioning

When commercial power is present, the UPS supplies conditioned power to the load while maintaining its batteries in a charged condition. The UPS protects against the normal, everyday problems associated with heavy use of raw commercial power, including power sags, surges, signal interference, and spikes. This protection keeps power-line problems from reaching your load, where they can cause equipment to operate erratically, or damage software and hardware.

## Inspection/Storage/Disposal

### Inspection

Upon receipt of the UPS, an inspection for shipping damage should be performed. Use caution when removing the unit from the pallet. Refer to labels or documentation attached to packing material.

### Unpacking

Check the unit for loose, broken, bent or otherwise damaged parts. If damage has occurred during shipping, keep all original crating and packing materials for return to the shipping agent. The warranty does not apply to damage incurred during shipping. Ensure that the rated capacity and the model number specified on the nameplate conform to the order specifications.

### Storage

During periods of non-use, the following guidelines are recommended for storage.

#### Storage Preparation

1. Power up the UPS and allow it to operate with no load for 24 hours to fully charge the batteries.
2. Stop the unit (see Stop Operation on page 25).
3. Place the MCCB switch (see page 47 for location) in the Off position.

#### Storing Conditions

- For best results, store the UPS in the original shipping container and place on a wood or metal pallet.
- Storage temperature: -4 – 104 °F (-20 – 40 °C).
- The optimum storage temperature is 70 °F (21 °C). A higher ambient temperature will require recharging more frequently during storage.

Avoid storage locations that:

- Are subject to extreme temperature changes or high humidity.
- Are subject to high levels of dust or metal particles.
- Are subject to excessive vibration.
- Have inclined floor surfaces.

#### Storage Maintenance

- If stored at an ambient temperature less than 68 °F (20 °C), recharge the batteries every 9 months.
- If stored at an ambient temperature of 68 – 86 °F (20 – 30 °C), recharge the batteries every 6 months.
- If stored at an ambient temperature of 86 – 104 °F (30 – 40 °C), recharge the batteries every 3 months.

### Disposal

Please contact your local or state environmental agency for details on disposal of electrical components and packaging in your particular area.

**It is illegal to dump lead-acid batteries in landfills or dispose of improperly.**

Please help our Earth by contacting the environmental protection agencies in your area, the battery manufacturer, or call Toshiba toll-free at (877) 867-8773 for more information about recycling.

## Installation Precautions



### CAUTION

1. Install the unit in a well-ventilated location; allow at least 4 inches (10 cm) on all sides for air ventilation and for maintenance.
2. Install the unit in a stable, level and upright position that is free of excessive vibration.
3. Install the unit where the ambient temperature is within the range specified on pages 16 and 19.
4. DO NOT install the UPS in areas that are subject to high humidity.
5. DO NOT install the UPS in areas that allow exposure to direct sunlight.
6. DO NOT install the UPS in areas that allow exposure to high levels of airborne dust, metal particles, or flammable gases.
7. DO NOT install the UPS in areas near sources of electrical noise. Ensuring a proper earth ground will reduce the effects of electrical noise and will reduce the potential for electrical shock.
8. DO NOT install the UPS in areas that would allow fluids or any foreign object to get inside the UPS.
9. The UPS generates and can radiate radio-frequency energy during operation. Although RFI noise filters are installed inside of the unit, there is no guarantee that the UPS will not influence some sensitive devices that are operating near by. If such interference is experienced, the UPS should be installed farther away from the affected equipment and/or powered from a different source than that of the affected equipment.
10. The user should provide output over-current protection for hardwired UPS systems. See the section titled Specifications on page 15 and 18 for the device rating.
11. After ensuring that all power sources are turned off and isolated in accordance with established lockout/tagout procedures, connect the power source wiring of the correct voltage to the input terminals of the UPS.
12. Connect the output terminals of the UPS to the load (refer to NEC Article 300 – Wiring Methods and Article 310 – Conductors For General Wiring). Size the branch circuit conductors in accordance with NEC Table 310.16.

## Conductor Routing and Grounding

1. Use separate metal conduits for routing the input power, output power, and control circuits.
2. Follow the wire size and tightening torque specifications listed on page 11.
3. Always ground the unit to reduce the potential for electrical shock and to help reduce electrical noise.
4. A separate ground cable should be run inside the conduit with the input power, output power, and control circuits.



### WARNING



**THE METAL OF CONDUIT IS NOT AN ACCEPTABLE GROUND.**

## Operating Precautions

1. The UPS should not be powered up until the entire operation manual has been read.
2. The voltage of the input power source must be within the range of +10% to -30% of the rated input voltage. The input frequency must be within the rated input frequency range. Voltages and frequencies outside of the permissible range may activate the internal protection devices.
3. The UPS should not be used with a load that has a rated input that is greater than the rated output of the UPS.
4. DO NOT use the UPS to provide power to motors that require high starting current or with motors that require a long starting time, such as vacuum cleaners and machine tools (oversizing the UPS for lock rotor current would be required).
5. DO NOT insert metal objects or combustible materials in the ventilation slots of the UPS.
6. DO NOT place, hang, or paste any objects on the exterior surfaces of the UPS.
7. The capacitors of the UPS maintain a residual charge for a while after turning the UPS off. The required discharge time for each UPS typeform is provided via a cabinet label and a **CHARGE LED**. Wait for at least the minimum time indicated on the label and ensure that the **CHARGE LED** has gone out before opening the door of the UPS once the UPS power has been turned off.
8. DO NOT attempt to disassemble, modify, or repair the UPS. Call your Toshiba sales representative for repair information.
9. Turn the power on only after installing ALL of the covers.
10. DO NOT remove any covers of the UPS when the power is on.
11. If the UPS should emit smoke, produce an unusual odor, or make sound, turn the power off immediately.
12. The heat sink and other components may become extremely hot to the touch. Allow the unit to cool before touching these items.
13. Warning signs should be placed on or near the load as a notification that the load is being powered by the UPS.
14. Additional warnings and notifications shall be posted at the equipment installation location as deemed required by **Qualified Personnel**.



### WARNING

When operating in the inverter mode, placing the breaker in the **OFF** position will switch the UPS to the battery backup mode. The output of the UPS will continue uninterrupted to the load. The unit must be in the bypass mode at the time that the breaker is placed in the **OFF** position for the UPS to shutdown power to the load.



### CAUTION

Wait at least 5 minutes after an Emergency Power Off (EPO) before resetting the UPS breaker. This allows the UPS circuitry to fully discharge. The UPS could be damaged if the unit is not fully discharged before the breaker is reset.

## Equipment Warning Labels

Below and on the following page are examples of warning labels that may be attached to either the interior or exterior of the UPS. Do not remove or cover any of the labels. If the labels are damaged or if additional labels are required, contact your equipment representative for additional labels.

These labels are placed to provide useful information or to indicate an imminently hazardous situation that may result in severe equipment/property damage, serious injury, or loss of life if instructions are not followed.

48518

 **DANGER/ATTENTION**

 Risk of electrical shock. Do not touch uninsulated battery terminals. Batteries should be serviced by qualified service representative only. Miswiring of battery could result in electrical shock and/or fire.

Risque de choc électrique. Le circuit des batteries n'est pas isolé secteur. Les cosses des batteries peuvent présenter une tension dangereuse par rapport à la terre. Vérifier avant de toucher.

 **DANGER**

 Battery fuse is always live. Risk of electrical shock. Check fuse voltage and disconnect external batteries before changing fuse.

48524

 **CAUTION/ATTENTION**

*Risk of electric shock. Do not remove cover. **NO USER SERVICEABLE PARTS INSIDE.** Refer servicing to qualified service personnel.*

*To reduce the risk of fire or electric shock, install in a temperature and humidity controlled indoor area free of conductive contaminants.*

*En cas utilisation en atmosphère contrôlée. Consulter la notice technique.*

*Note: Service personnel only.  
Hazardous live parts inside the UPS are energized from the battery supply even when the input AC power is disconnected.*

*Capacitors store hazardous energy. Do not remove cover until 5 minutes after disconnecting all sources of supply.*

---

*Battery backup time, which was factory-set at a predetermined level, decreases gradually between service periods. The batteries should be replaced every three years after the last servicing, the date of which is written on the ID plate located on the rear side of the UPS unit, or in the boxes below.*

Date of last battery charge:

 **CAUTION/ATTENTION**

*Do not disconnect while unit is operating on battery power. Nes pas débrancher sous charge.*



 **CAUTION**

*HOT SURFACE. Contact may result in burn injury. Allow equipment to cool before servicing.*







 **CAUTION/ATTENTION**



*Heat sink not grounded. Risk of electrical shock. Disconnect UPS and electrically test heat sink before touching.*





49455

 <b>WARNING</b>	
	<p><b>This unit contains sealed lead acid batteries.</b> Lack of preventative maintenance could result in batteries exploding and emitting gasses and/or flame. Annual preventative maintenance must be performed by an authorized, trained technician.</p>

 <b>WARNING</b>	
	<p><b>CRITICAL FUSE SIZING</b> Incorrect fuse replacement size may result in fire or inadequate equipment protection. Replace only with same type and rating of fuse.</p>

 <b>WARNING</b>	
	<p><b>EXTERNAL BATTERY CABINET</b> The battery cabinet must have a nominal battery voltage of 288VDC and 30ADC MAX.</p> <p style="text-align: right;">PN 51727</p>

1600 EP UPS 8.0KVA & 10KVA/220V only

 <b>WARNING</b>	
	<p><b>EXTERNAL BATTERY CABINET</b> The battery cabinet must have a nominal battery voltage of 288VDC and 75ADC MAX.</p> <p style="text-align: right;">PN 53495</p>

1600 EP UPS 14KVA, 18.0KVA, 22KVA &  
1600 EP 8-18KVA BATT. CABINET only

## UPS Connections

### Terminal Block

The following illustration is a detail view of the terminal block and wiring connections used for 208/240 volt units (see pages 49-50 for terminal block location).

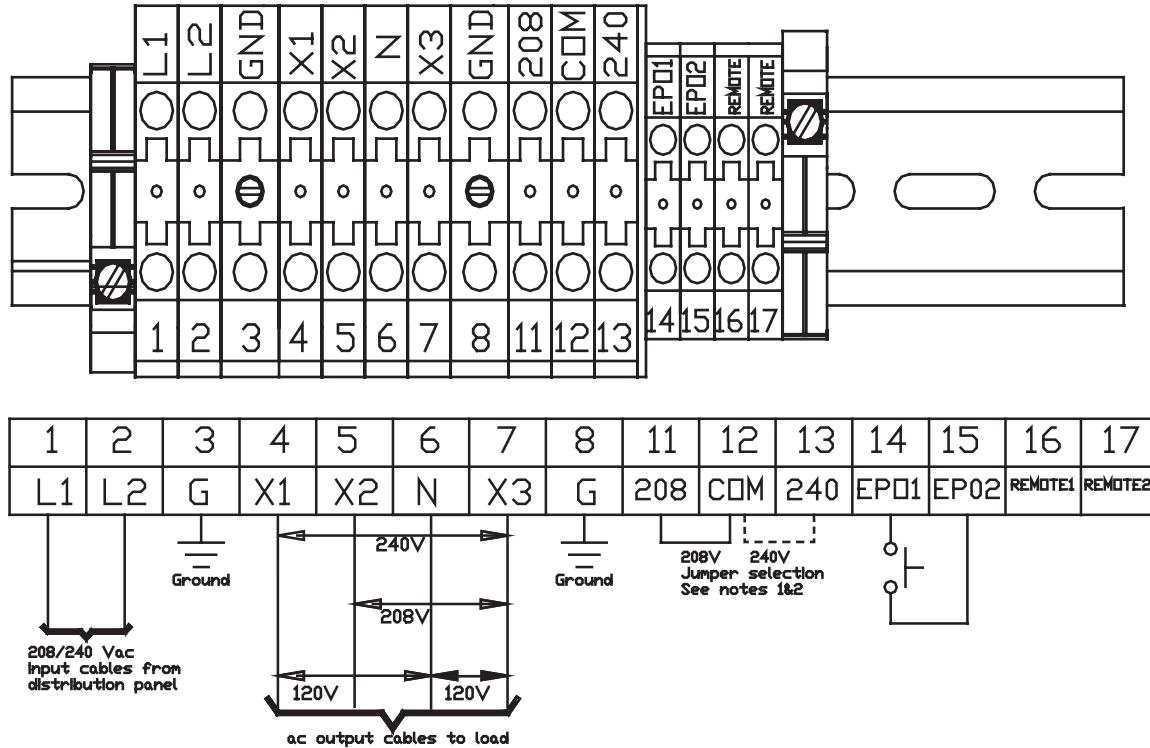

NOTE 1 – If AC input power is 208 Vac rated, short terminals 11 and 12 with a jumper wire. DO NOT jumper terminal 13 to 12 or 11. Factory Setting is 208Vac. **Use the jumper wire provided by Toshiba. DO NOT add any additional jumpers.**

NOTE 2 – If AC input power is 240 Vac rated, short terminals 12 and 13 with a jumper wire. DO NOT jumper terminal 11 to 12 or 13. **Use the jumper wire provided by Toshiba. DO NOT add any additional jumpers.**

### Wire Size and Tightening Torque

Use the following table to select the recommended wire size and terminal lug tightening torque for I/O wire connections.

Item	Terminal Number	AWG 3.6-RoHS kVA	AWG 3.6 kVA	AWG 6 kVA	AWG 8 kVA	AWG 10 kVA	AWG 14-18 kVA	AWG 22 kVA	Tightening Torque lb.-in. (N·m)
AC Input Lines	1 and 2	12 (8)	12 (8)	10 (8)	8 (1/0)	6 (1/0)	4 (1/0)	1 (1/0)	14.2 (1.56)
AC Output Lines	4, 5, and 7	12 (8)	12 (8)	10 (8)	8 (1/0)	6 (1/0)	4 (1/0)	1 (1/0)	14.2 (1.56)
AC Output Neutral	6	12 (8)	12 (8)	10 (8)	8 (1/0)	6 (1/0)	4 (1/0)	1 (1/0)	14.2 (1.56)
Ground	3 and 8	12 (8)	12 (8)	10 (8)	8 (1/0)	6 (1/0)	4 (1/0)	1 (1/0)	14.2 (1.56)
EPO Switch	14 and 15	16	16	16	16	16	16	16	9.0 (0.99)
Remote Switch	16 and 17	16	16	16	16	16	16	16	9.0 (0.99)

Note: Wire size presented as the recommended size followed by a bold number in ( ) that is the maximum wire size the terminal block can accommodate. See page 48 for knock-out hole sizes on the back of each model.

## Communication Interfaces

### Remote Contacts

The remote contacts interface is provided as a set of solid state relay switch contacts. The switches are available through a DB9 male connector on the rear of the UPS. The following chart shows the pin assignment for each signal.

MAXIMUM CURRENT CARRYING CAPACITY OF THE SWITCH

Voltage	Current
48 Vdc Peak	100 mA peak
30 Vac rms (42 Vac peak)	70 mA rms (100 mA peak)

DB9 MALE CONNECTOR OUTLINE (FACING CONNECTOR)

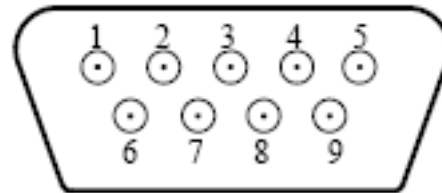

Pin	Signal Function	Logic	In the UPS
1	Fault Signal	Closed when fault detected	
2	UPS stop common	Backup stop when the level changes from Low (-3 to -15 V) to High (+3 to +15 V)	
3	UPS stop signal input		
4	Normal input power supply	Closed with normal supply power	
5	Signal common	Common signal return	
6	Bypass operation	Closed during bypass operation	
7	Battery voltage drop	Closed at voltage drop	
8	UPS operation	Closed during inverter operation	
9	Power failure signal	Closed at power failure	

**NOTE** Pin switches are shown in their inactive states. For example, if battery voltage is low, pin 7 will be connected to pin 5.

### UPS Stop Signal Operation

When the UPS stop signal is sent to the UPS through pin 2 and 3 of the external contact interface, it is possible to automatically reset the following operating systems (OS), which can automatically implement the shutdown function and restart the operation:

**Applicable OS: Windows NT, IBM OS/2 LAN server, LANtastic**

When the power fails, the OS receives the power failure signal from the UPS and starts the shutdown process. At the end of the OS shutdown process, the OS sends a stop signal to the UPS, and the UPS stops. When the power recovers, the UPS automatically restarts the OS within 10 minutes after the recovery from power failure.

If the line power recovers while the OS is in the shutdown process, the OS continues the shutdown process, and signals the UPS to stop. The UPS temporarily cuts off the output (10 - 20 seconds) and then restarts the OS. In this case the UPS cuts off output even with normal input power.

If the OS sends a stop signal to the UPS 10 or more minutes after recovery from a power failure, the UPS will ignore the signal and continue normal operation.

Connect only the UPS stop signal to the external contact interface for automatic processing so that the UPS output will not be turned off by mistake.

**If the computer is started/restarted within 10 minutes after the recovery from a power failure, the power supply may be reset while the computer is restarting.**

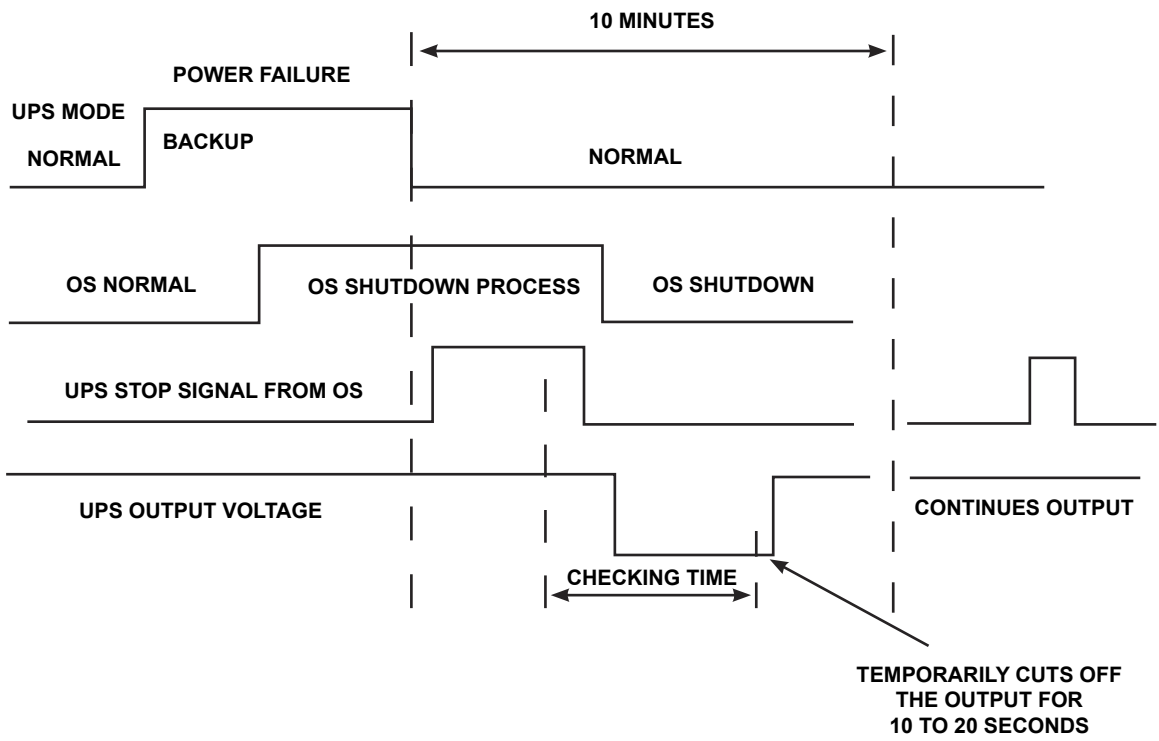

## RS-232C

The RS232C port can be used by authorized service personnel. The port is provided using a DB9 female connector located on the rear of the UPS. For reference, the pinout of the connector is illustrated below.

**RS-232C CONNECTOR PIN ASSIGNMENT**

Pin	I/O	Symbol	Description
1	This pin is not used		
2	Input	RXD	Receive data
3	Output	TXD	Transmit data
4	Output	DTR	Data terminal ready
5	-	SG	Signal ground
6	Input	DSR	Data set ready
7	Output	RTS	Request to send
8	Input	CTS	Clear to send
9	This pin is not used		

**DB9 FEMALE CONNECTOR OUTLINE  
(FACING CONNECTOR)**

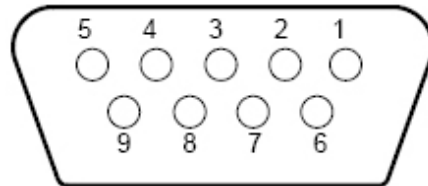

## RemotEye II Network Card

The RemotEye II is an optional network card for the Toshiba UPS. This card slides into a slot located on the back side (pages 47-48) of the UPS. The card provides a network, or LAN-based communication interface for the UPS. When installed, the UPS can be managed remotely using the common SNMP and HTTP web-based network protocols. The following diagram shows the flow of the Network Management Station.

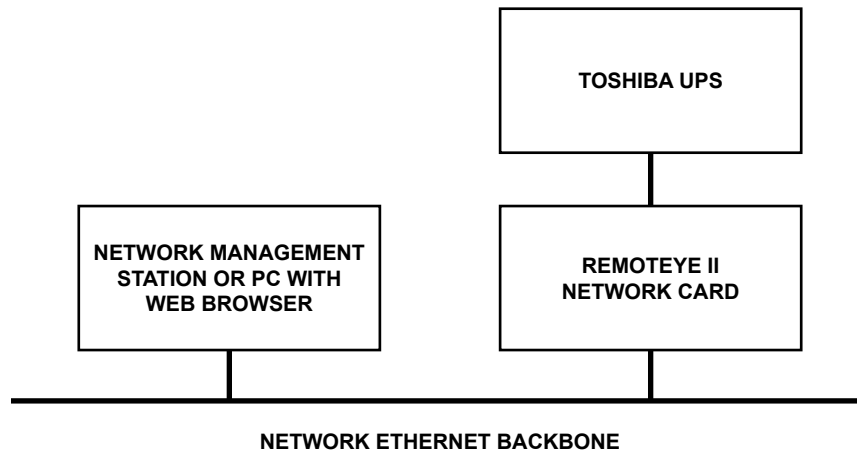

**NOTE** The UPS communication mode setting must be set to SNMP mode when using the RemotEye network card (see Comm Mode variable in the Data Setting screens on page 33).

## UPS Specifications

### STANDARD MODELS: 3.6kVA-RoHS; 3.6kVA; 6kVA; 8kVA

Unit (Capacity)	3.6 kVA-RoHS (3.1 kW) <sup>1</sup>	3.6 kVA (3.1 kW) <sup>1</sup>	6 kVA (5.1 kW) <sup>1</sup>	8 kVA (6.8 kW) <sup>1</sup>
<b>General</b>				
Topology	True On-line			
Certifications	UL, CUL, ISO 9001, NEMA/PE1-1993			
<b>Input Characteristics</b>				
Input Voltage <sup>1</sup>	Single-phase, 208/240 Vac +10% to -30% <sup>1</sup>			
Input Frequency	45 – 65 Hz (auto-sensing)			
Input Capacity	3.6 kVA		6.0 kVA	8.0 kVA
Input Power Factor	> 0.95 for all loads			
Current THD (linear load)	< 5% total harmonic distortion			
Included AC Input Breaker Rating	30 A/277 V		50 A/277 V	60 A/277 V
<b>Battery Characteristics</b>				
Battery Type	Valve Regulated Lead Acid, Flame Retardant			
Backup time, fully charged @ 0.7 power factor, 77 °F	8 min. minimum <sup>2</sup>	14 min. minimum <sup>2</sup>	7 min. minimum <sup>2</sup>	
Backup time, fully charged @ 0.85 power factor, 77 °F	7 min. minimum <sup>2</sup>	10 min. minimum <sup>2</sup>	7 min. minimum <sup>2</sup>	
Recharge Time	24 hr. (full), 12 hr. (90%) for internal batteries only <sup>3</sup>			
Battery Voltage (Nominal)	144 Vdc	216 Vdc	216 Vdc	288 Vdc
<b>Output Characteristics</b>				
Output Voltage	Single-phase, 240/208/120 V			
Output Voltage Regulation	± 3%			
Output Frequency	±0.5 Hz/1 Hz/1.5 Hz (factory or authorized service center selectable only)			
AUTO/MAN Frequency	Factory or authorized service center selectable only			
Voltage THD	< 3% for linear load; < 6% for non-linear load			
Common-Mode Noise	< 0.5 Vrms			
Rated Load Power Factor	0.85 (0.6 – 1.0) lagging			
Efficiency (ac-dc-ac)	> than 83% (without battery charge)			
Voltage Transient	< ±8% (Load of 0 – 100 %)			
Rated Output Current (rms)	15 A		25 A	33.3 A
Max. Peak Output Current	45 A		75 A	100 A
Inverter Overload Capacity	125% for 30 sec./150% for 10 sec.			
Bypass Overload Capacity	125% for 10 min./1000% for 1 cycle			
Crest Factor	3.0			

1. Input/output figures rated for 240 volts. Output ratings given for 0.85PF are only valid when the input voltage is greater than 204 volts; otherwise, ratings given for 0.70PF are applicable.
2. Battery backup time may vary depending on the operating conditions and ambient temperature at the installation site.
3. An initial charge time of 24 hrs. is necessary to obtain proper battery performance level before unit is placed in operation.

**STANDARD MODELS: 3.6kVA-RoHS; 3.6kVA; 6kVA; 8kVA (CONT'D)**

Unit (Capacity)	3.6 kVA-RoHS (3.1 kW) <sup>1</sup>	3.6 kVA (3.1 kW) <sup>1</sup>	6 kVA (5.1 kW) <sup>1</sup>	8 kVA (6.8 kW) <sup>1</sup>
<b>Environment</b>				
Operating Temperature 59 – 77 °F (15 – 25 °C) recommended	60 Hz		50 Hz	
	32 – 104 °F (0 – 40 °C)		32 – 91 °F (0 – 33 °C)	
Storage Temperature	-4 – 104 °F (-20 – 40 °C)			
Installation Area	To be installed in a well ventilated area free of airborne dust, metal particles or flammable gas, allow at least 4 inches on all sides			
Operating Humidity	30 – 90% non-condensing			
Altitude	< 3300 ft. (1000 m) above sea level <sup>2</sup>			
Acoustical Noise	50 dB (A) maximum @ 1 meter from front panel			
Heat Generation	1588 BTU/Hr	1588 BTU/Hr	2610 BTU/Hr	3482 BTU/Hr
<b>Operation Diagnosis</b>				
Battery Check	Performed on start up, by schedule, on-demand (user configurable)			
Input OV Protection	Standard			
Battery Lifetime	UPS calculates battery replacement time based upon battery ambient temperature (LCD display, LED and beeps)			
Internal Temperature	UPS gives indication of internal temperature, alarm when high temp			
Event Data Storage	64 – Supply Mode, 32 – Backup, 16 – Faults			
<b>Applications</b>				
Switches	Generator compatibility			
<b>Bypass Switch</b>				
Bypass Disable	Static switch < ¼ cycle (50 Hz – 5 ms/60 Hz – 4.16 ms)			
Automatic Retransfer	Factory or authorized service center selectable only			
User Interface	Provided – Can be disabled from front panel			
<b>Real Time Clock</b>				
Schedule Operation	Standard – Minimum 3 days memory backup during power loss			
RUN/STOP Disable	Schedule ON/OFF operation of UPS using communication software			
Autostart	UPS has option for UPS to start automatically when AC is applied			
Remote ON/OFF	Standard – External terminal			
LED Display	4 LED's indicating input/output condition, warning and battery operation			
LCD Screen	16 characters x 2 lines			
UPS Operation: 6 Keys	Run/Stop, Set/Monitor, Shift/Select, Del/Page Down, Reset/Page Up			
Buzzer Volume	Selectable by keypad – Low, High, Mute			
Power Connections	Standard – Hard wire			
Emergency Power Off	Standard – Terminal contacts only			
Remote Contacts	Standard (INV, BYP, BATT, LB, AC, FLT)			
RS232 ASCII Interface	Standard			

1. Input/output figures rated for 240 volts. Output ratings given for 0.85PF are only valid when the input voltage is greater than 204 volts; otherwise, ratings given for 0.70PF are applicable.
2. At 6600 ft (2000 m) above sea level, output capacity should be derated by 3%

**STANDARD MODELS: 3.6kVA-RoHS; 3.6kVA; 6kVA; 8kVA (CONT'D)**

Unit (Capacity)	3.6 kVA-RoHS (3.1 kW) <sup>1</sup>	3.6 kVA (3.1 kW) <sup>1</sup>	6 kVA (5.1 kW) <sup>1</sup>	8 kVA (6.8 kW) <sup>1</sup>
<b>Mechanical Design</b>				
Topology	Unit enclosure is made from sheet metal meeting NEMA1 and UL Type 1			
Size (HxWxD) (max)	22.1 x10 x 33 in. (533x254x838 mm)	27.5 x 10.0 x 33.0 in. (698 x 254 x 838 mm)		28.4x 13 x 33.5 in. (721 x 330 x 851 mm)
Paint System	Powder coating			
Fan Panel	Panel mounted on back of UPS to allow for easy replacement of fans without turning UPS off.			
<b>Battery System</b>				
Battery Replacement	Slide out battery packs accessible from front of UPS. Factory or authorized service center serviceable only.			
Battery Packs	Designed for battery acid leakage containment with six (6) batteries per pack.			
Battery Pack Size (HxWxD) max.	5 x 7.3 x 18.2 in. (127 x 185 x 462 mm)			
Battery Pack Quantity	2	3	4	
Battery Manufacturer	Yuasa			
Battery Type	REW-45			
Toshiba's Part Number for Battery Pack	51896			

1. Input/output figures rated for 240 volts. Output ratings given for 0.85PF are only valid when the input voltage is greater than 204 volts; otherwise, ratings given for 0.70PF are applicable.

**STANDARD MODELS: 10kVA; 14kVA; 18KVA; 22kVA**

Capacity	10 kVA (8.5 kW) <sup>1</sup>	14 kVA (11.9 kW) <sup>1</sup>	18 kVA (15.3 kW) <sup>1</sup>	22 kVA (18.7 kW) <sup>1</sup>
<b>General</b>				
Topology	True On-line			
Certifications	UL, CUL, ISO 9001, NEMA/PE1-1993			
<b>Input Characteristics</b>				
Input Voltage <sup>1</sup>	Single-phase, 208/240 VAC, +10% to -30% <sup>1</sup>			
Input Frequency	45-65 Hz (auto-sensing)			
Input Capacity	10 kVA	14 kVA	18 kVA	
Input Power Factor	> 0.95 for all loads			
Current THD (linear load)	< 5%			
Included AC Input Breaker rating	63 A / 277 V	100 A / 277 V		125 A / 277 V
<b>Battery Characteristics</b>				
Battery Type	Valve Regulated Lead Acid, Flame Retardant			
Backup time, fully charged @ 0.7 power factor, 77 F	10 kVA	14 kVA	18 kVA	22 kVA
	7 min minimum <sup>2</sup>			5 min
Backup time, fully charged @ 0.85 power factor, 77 F	5 min minimum <sup>2</sup>	7 min minimum <sup>2</sup>	5 min minimum <sup>2</sup>	3 min minimum <sup>2</sup>
	24hr. (full), 12hr.(90%) for internal batteries only <sup>3</sup>			
Recharge Time	24hr. (full), 12hr.(90%) for internal batteries only <sup>3</sup>			
Battery Voltage (Nominal)	288 VDC			
<b>Output Characteristics</b>				
Output Voltage	Single-phase, 240/208/120 volts			
Output Voltage Regulation	±3%			
Output Frequency	±0.5Hz/1Hz/1.5Hz (factory or authorized service center selectable only)			
AUTO/MAN Frequency	Factory or authorized service center selectable only			
Voltage THD	< 3% for linear load; < 6% for non-linear load			
Common-Mode Noise	< .5 Vrms			
Rated Load Power Factor	0.85 (0.6 - 1.0) lagging			
Efficiency (AC-DC-AC)	> 83% (without battery charge)			
Voltage Transient	< ±8% (Load of 0 to 100 %)			
Rated Output Current (rms)	41.6 A	58.0 A	75.0 A	91.6 A
Max. Peak Output Current	125 A	174 A	225 A	275 A
Inverter Overload Capacity	125%-30 sec/150%-10 sec			
Bypass Overload Capacity	125%-10 min./1000%-1 cycle			
Crest Factor	3.0			

1. Input/output figures rated for 240 volts. Output ratings given for 0.85PF are only valid when the input voltage is greater than 204 volts; otherwise, ratings given for 0.70PF are applicable.
2. Battery backup time may vary depending on the operating conditions and ambient temperature at the installation site.
3. An initial charge time of 24 hrs. is necessary to obtain proper battery performance level before unit is placed in operation.

**STANDARD MODELS: 10kVA; 14kVA; 18KVA; 22kVA (CONT'D)**

Capacity	10 kVA (8.5 kW) <sup>1</sup>	14 kVA (11.9 kW) <sup>1</sup>	18 kVA (15.3 kW) <sup>1</sup>	22 kVA (18.7 kW) <sup>1</sup>
<b>Environment</b>				
Operating temperature (15 – 25° C recommended)	60 Hz (0 – 40 °C) ; 50Hz (0 – 33 °C)			
Storage Temperature	-20 – 40 °C (-4 – 104 °F)			
Installation Area	To be installed in a well ventilated area free of airborne dust, metal particles or flammable gas, allow at least 4 inches on all sides			
Operating Humidity	30 – 90% (no condensation)			
Altitude	< 3200 ft. (1000 m) above sea level <sup>2</sup>			
Acoustical Noise	50 dB (A) maximum @ 1 meter from front panel			
Heat Generation	4352 BTU/Hr	6092 BTU/Hr	7832 BTU/Hr	9600 BTU/Hr
<b>Operation Diagnosis</b>				
Battery Check	Performed on start up, by schedule, on-demand (user configurable)			
Input OV Protection	Standard			
Battery Lifetime	UPS calculates battery replacement time based upon battery ambient temperature (LCD display, LED and beeps)			
Internal Temperature	UPS gives indication of internal temperature, alarm when high temp			
Event Data Storage	64-Supply Mode, 32-Back up, 16-Faults			
<b>Applications</b>				
Switches	Generator compatible			
<b>Bypass Switch</b>				
Bypass Disable	Static switch <1/4 cycle (50Hz: 5 ms/60Hz: 4.16 ms)			
Automatic Retransfer	Factory or authorized service center selectable only			
User Interface	Provided – Can be disabled from front panel			
<b>Real Time Clock</b>				
Schedule Operation	Standard – Minimum 3 days memory backup during power loss			
RUN/STOP Disable	Schedule ON/OFF operation of UPS using communication software			
Autostart	UPS has option for UPS to start automatically when AC is applied			
Remote ON/OFF	Standard – External terminal			
LED Display	4 LED's indicating input/output condition, warning and battery operation			
LCD Screen	16 characters x 2 lines			
UPS Operation: 6 Keys	Run/Stop, Set/Monitor, Shift/Select, Del/(page down), Reset/(page up)			
Buzzer Volume	Low, High, Mute; Selectable by keypad			
Power Connections	Standard – Hard wire			
Emergency Power Off	Standard – Terminal contacts only			
Remote Contacts	Standard (INV, BYP, BATT, LB, AC, FLT)			
RS232 ASCII Interface	Standard			

1. Input/output figures rated for 240 volts. Output ratings given for 0.85PF are only valid when the input voltage is greater than 204 volts; otherwise, ratings given for 0.70PF are applicable.
2. At 6600 ft (2000 m) above sea level, output capacity should be derated by 3%

**STANDARD MODELS: 10kVA; 14kVA; 18KVA; 22kVA (CONT'D)**

Capacity	10 kVA (8.5 kW) <sup>1</sup>	14 kVA (11.9 kW) <sup>1</sup>	18 kVA (15.3 kW) <sup>1</sup>	22 kVA (18.7 kW) <sup>1</sup>
<b>Mechanical Design</b>				
Enclosure	Enclosure of unit made from sheet metal meeting NEMA1 and UL Type 1			
Size (HxWxD) (max)	28.4 x 13 x 33.5 in. (721 x 330 x 851 mm)	39.1 x 17.5 x 34.8 in. (993 x 444 x 889 mm)		
Paint System	Powder coating.			
Fan Panel	Panel mounted on back of UPS to allow for easy replacement of fans without turning UPS off.			
<b>Battery System</b>				
Battery Replacement	Slide out battery packs accessible from front of UPS, factory or authorized service center serviceable only			
Battery Packs	Designed for battery acid leakage containment with (6) batteries per pack.			
Battery Pack Size (HxWxD) max.	5 x 7.3 x 18.2 in. (127 x 185 x 462 mm)			
Battery Pack Quantity	4	8		
Battery Manufacturer	Yuasa			
Battery Type	REW-45			
Toshiba Part Number for Battery Pack	51896			

1. Input/output figures rated for 240 volts. Output ratings given for 0.85PF are only valid when the input voltage is greater than 204 volts; otherwise, ratings given for 0.70PF are applicable.

## Operating the UPS

### Battery Backup Time and Discharge Process

The UPS batteries provide about 5-7 minutes of back-up time depending on the 1600EP unit kVA rating. These times are valid when the unit is operating under full load and at the rated power factor. The exact length of these times will depend on the UPS model used, condition of the batteries, amount and type of load, temperature and other variables. See battery backup time in 'Standard Specifications' beginning on pages 15-20.

The following illustration graphically shows the battery discharge process at full load conditions.

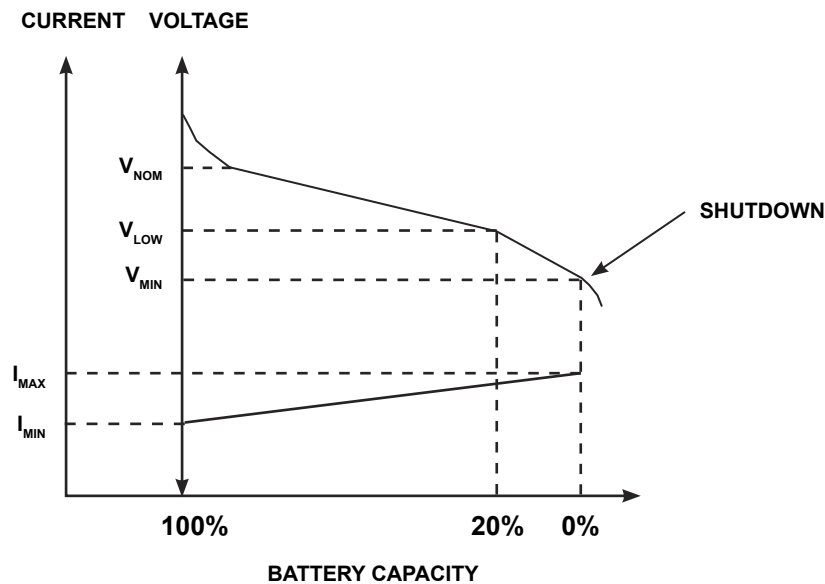

### Battery Low Voltage Tolerances

Excessive discharge will cause the UPS battery voltage to drop. The chart shown below lists the voltage level at which each UPS low-voltage alarm will sound and at what level the low-voltage condition will cause the unit to automatically shut down.

UPS Capacity	3.6 kVA -RoHS	3.6 kVA	6 kVA	8 kVA	10 kVA	14 kVA	18 kVA	22 kVA
Nominal voltage (Vnom)	144 Vdc	216 Vdc	216 Vdc	288 Vdc	288 Vdc	288 Vdc	288 Vdc	288 Vdc
Alarm voltage (Vlow)	130 Vdc	192 Vdc	192 Vdc	246 Vdc	246 Vdc	246 Vdc	246 Vdc	246 Vdc
Shutdown voltage (Vmin)	114 Vdc	170 Vdc	170 Vdc	227 Vdc	227 Vdc	227 Vdc	227 Vdc	227 Vdc

## Starting the UPS

Turn the main circuit breaker (MCCB) on the back of the UPS (see pages 47-48) to the **ON** position. The breaker should normally remain in the **ON** position.

Verify that the **ON-LINE** LED on the front panel (see page 32 and 33) lights green. All LED's on the front panel may light for a moment when the input breaker is turned on. This is normal. The UPS will now be supplying power in the bypass mode.



### CAUTION

**When running the UPS for the first time or after the power failure backup operation, charge the batteries for at least 24 hours (input breaker on) before operating the connecting load.**

Using the UPS without charging the battery shortens the battery backup operation time, which may result in the destruction of data in case of a power failure.

Press **RUN** key to begin UPS operation (see page 29 for startup screens).



### CAUTION

**If the input breaker is turned off while UPS is in the bypass state, the output power stops. Any load devices will lose power.**

Ensure that all sensitive loads have been previously shut down.

## Stopping the UPS

To stop the UPS press and hold the **STOP** key approximately 1 second until the **ON-LINE** LED changes from green to off. The UPS is now in the bypass mode.

To completely stop the UPS, turn the input breaker at the back of the UPS to the **OFF** position.

### Battery Recharging

The illustration below shows a graphical representation of the UPS battery recharge process after a full discharge.

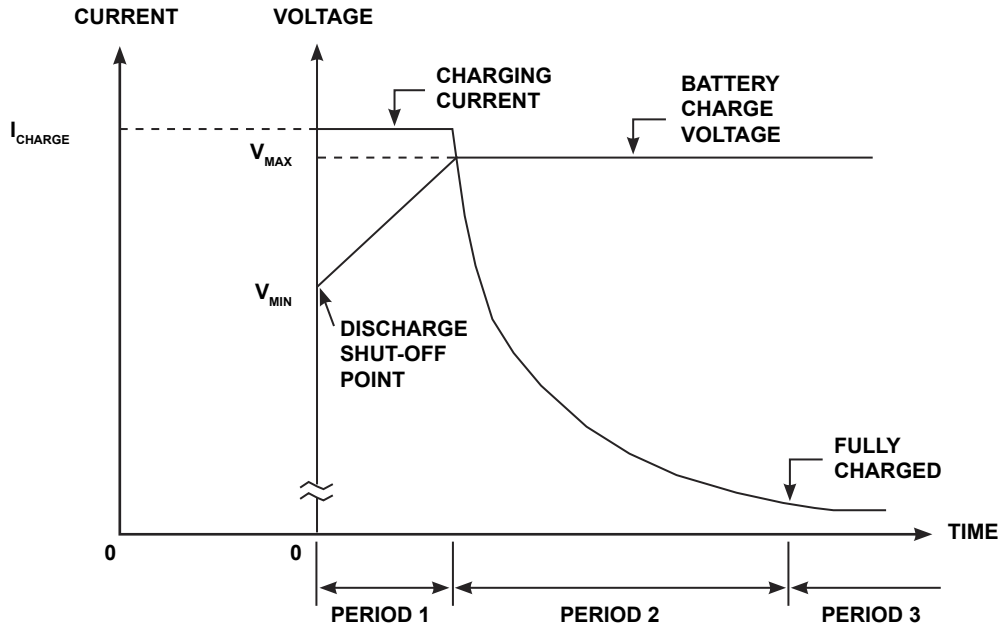

The recharge process usually consists of three periods. During the first period, the current is maintained at approximately 1 ampere. This current limit is the maximum value that can be used to charge the batteries (for minimal recharge time) while assuring safety and long battery life. In the second period, constant-voltage control starts and current gradually decreases as the batteries charge to their normal fully charged state. In the third period, a slight trickle current continues to flow into the batteries to keep them fully charged and floating at the normal V<sub>dc</sub> level. A full recharge usually requires 24 hours (90% recharge in 12 hours) after a complete discharge.

The following chart shows the rated maximum and minimum battery voltages and the charge current for each of the sizes.

**RATED BATTERY VOLTAGES**

Model	V <sub>max</sub>	V <sub>min</sub>	I <sub>charge</sub>
3.6 kVA-RoHS	163 V	114 V	1.0 A
3.6 kVA	245.7 V	170 V	1.0 A
6 kVA	245.7 V	170 V	1.0 A
8 kVA	327 V	227 V	1.0 A
10 kVA	327 V	227 V	1.0 A
14 kVA	327 V	227 V	1.0 A
18 kVA	327 V	227 V	1.0 A
22 kVA	327 V	227 V	1.0 A

## Online Mode

### Online Mode (Run operation)

The following illustration shows circuit power flow when the UPS is operating normally in the Online mode. The UPS rectifier, including a boost chopper circuit, converts AC input power to DC power. The boost chopper circuit maintains a constant voltage, with current limiting, for charging the batteries. It also supplies a DC voltage of the proper level to the inverter section. The inverter section generates a high quality sine wave output voltage. The unit's batteries are always maintained in a constantly charged state when the UPS is in the run operation mode.

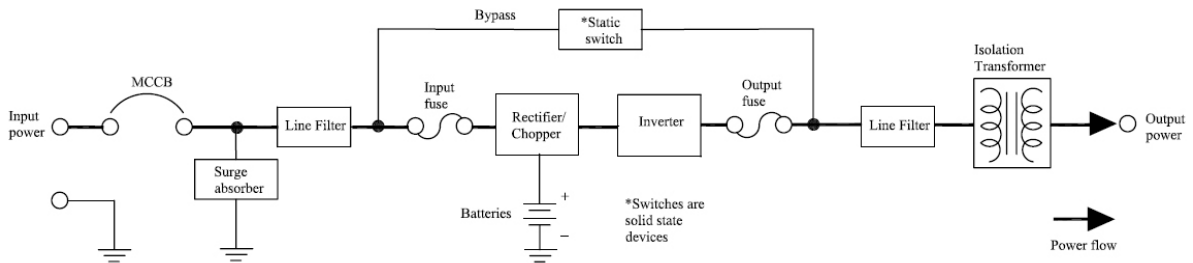

**POWER FLOW IN ONLINE MODE FOR ALL MODELS**

### Static-Bypass Mode (Stop operation)

If the UPS unit is severely overloaded or develops an internal fault, power flow is automatically switched from the unit's main circuit to the bypass circuit. Power flow through the bypass is shown in the following illustration. This change-over occurs automatically in phase in less than 4 milliseconds. The switching period is not long enough to cause interruptions to occur in most loads.

- If the power flow is transferred to the bypass circuit because of an overload and that overload condition ends within a specified period of time then the power flow will be transferred back to the **Online mode (run operation)** automatically.
- If the power flow is transferred to the bypass circuit due to an external fault the UPS will shut down power through the bypass to the load and indicate a system fault message.
- If the power flow is transferred to the bypass circuit due to an internal fault the UPS will continue to supply power to the load through the bypass and indicate a system fault message (see system fault message DC-OC on page 43).
- If the power flow is transferred to the bypass circuit due to an overload condition (see system warning message **OL: REDUCE LOAD** on page 39 and **AUTO RETRANSFER** on page 41), then the power flow will automatically transfer from the UPS's bypass circuit back to the inverter circuit after removing the overload if set to do so (see auto-transfer setting on page 35).

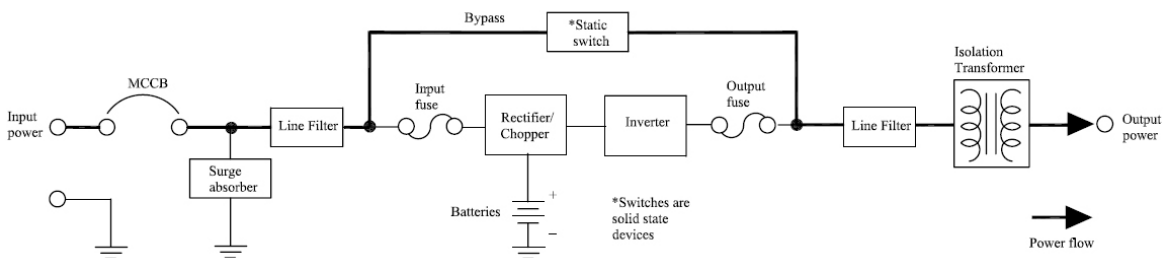

**POWER FLOW IN BYPASS MODE FOR ALL MODELS**

### Battery Backup Mode (On batteries)

The following illustration shows power flow during the battery backup mode. When commercial AC power failures occur, the UPS's batteries instantly begin supplying DC voltage to the UPS's main inverter circuit. This circuit changes (inverts) the DC power into AC power. The AC power is available at the output of the unit.

This back-up process will continue until the UPS's battery voltage drops below a specific minimum level. When this occurs, the batteries will stop supplying power to the load. This minimum level is the rated minimum voltage (Vmin). The rated battery voltage chart on page 23 shows (Vmin). The battery backup time and discharge process is explained on page 23.

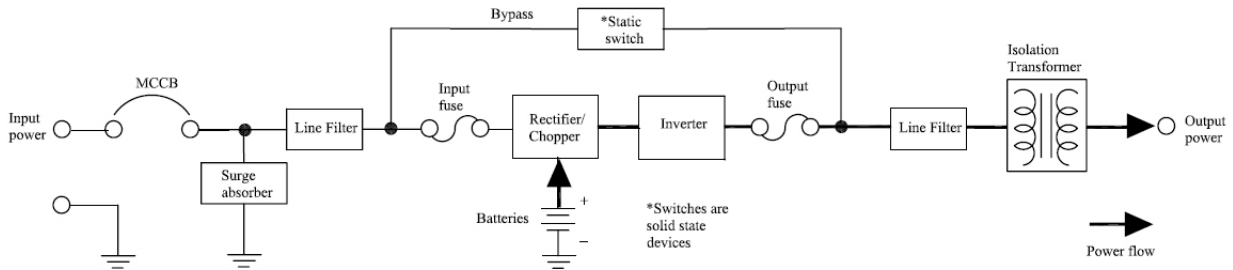

**POWER FLOW IN BATTERY BACKUP FOR ALL MODELS**

### EPO (Emergency Power Off) Function

These units are equipped with terminals for receiving an emergency power-off (EPO) command via a closed-contact switch at a remote location (see Terminal Block Details on page 11 and terminal block location on page 37-38). This safety feature enables quick shut-down of the UPS's AC output and battery circuits.

Usually the emergency power off switch is installed in a central location that is easily accessible to personnel concerned with the operation of the UPS unit and the load equipment connected to it. The EPO function is initiated by pressing the switch to the closed (shutdown) position.

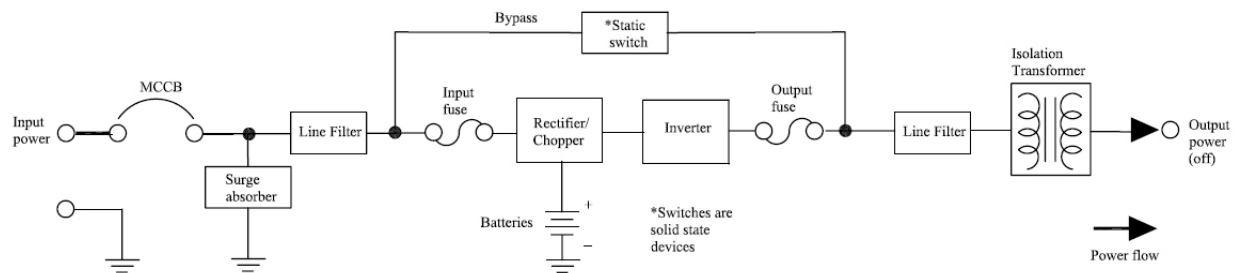

The effect of using the EPO switch is the same whether the UPS unit is in AC input mode (see page 24), battery backup mode (see page 25), or the circuit bypass mode (see page 24). The following figure shows the UPS condition after application of the EPO switch.



**POWER FLOW AFTER AN EPO COMMAND FOR ALL MODELS**

**Audible Alarm Functions**

Audible alarms will sound when the UPS is in the battery backup mode, has a fault, has low battery voltage, or is in an overload condition. The following chart shows the audible alarm pattern durations for each condition. Time units are shown in seconds.

The audible alarm can be silenced by pressing  +  key on the front panel (see page 27).

**AUDIBLE ALARMS**

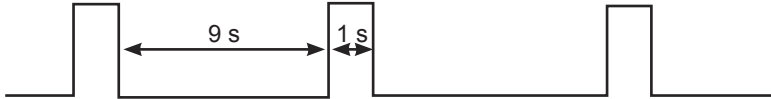
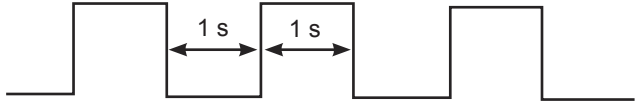
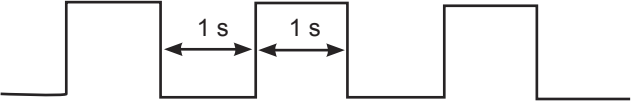
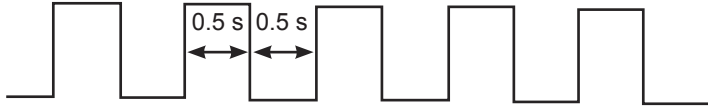
Condition	Audible Pattern
UPS in battery Backup mode	
UPS low Battery voltage	
Overload	
Fault	

## Display and Keys

### Front Panel Layout

The front panel consists of several elements for monitor and operation of the UPS. Panel components are shown in the illustration below:

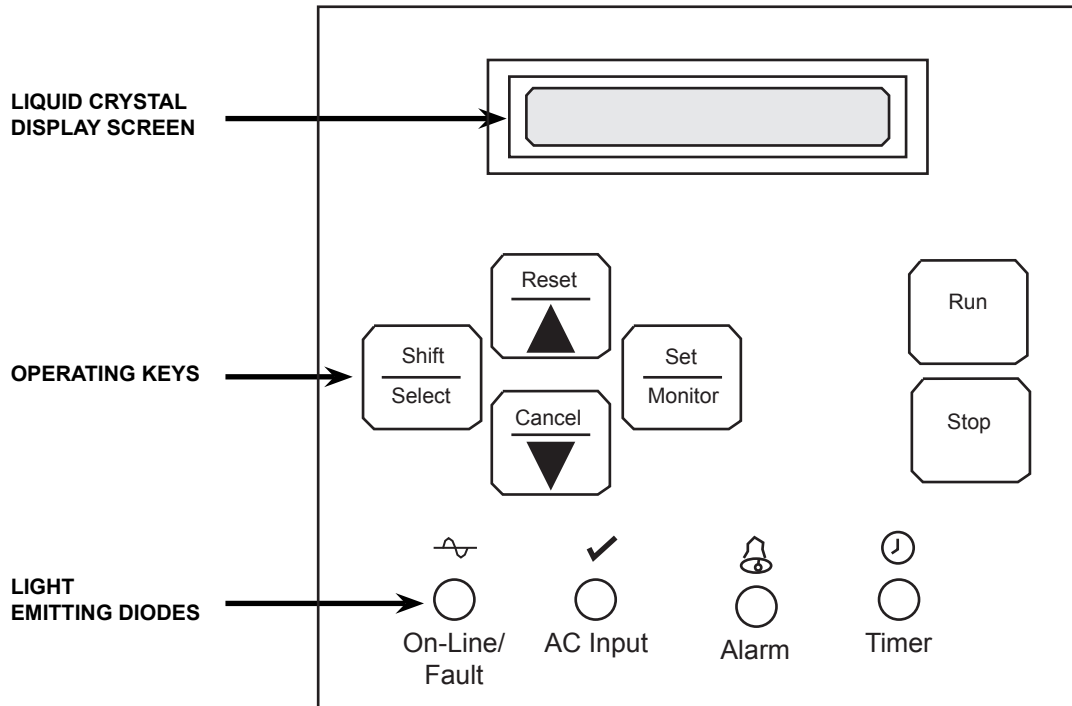







### Liquid Crystal Display (LCD) Functions

The LCD screen is a 2-line by 16-character wide liquid crystal display. The LCD displays information about the operation of the UPS. It should be used in conjunction with the LED display (see page 28, 39-40) and the audible alarms (see page 26) for total system monitoring. The LCD screen displays information which may be shown only on specific lines of the display. This information is determined by the UPS operating mode and conditions. These messages are shown in the LED displays and LCD screens on pages 28 through 41.





## Operating Keys

Refer to this illustration for all UPS front panel operating procedures.

Key	Functional Description
	Press and hold this key while pressing one of the other keys to execute the function marked above the upper line of the key. Pressing this key alone enters the mode set on the internal data setting LCD screen (see page 33).
	Scrolls the display upward or with shift key resets the display.
	Scrolls the display downward or with shift key cancels the preceding operation.
	Press and hold this key to view the Data Display screens (see page 31). Continue to press this key to access the Data Setting screens (see page 33).
	Runs the UPS or with shift key silences the trouble indicator audio alarm.
	Stops the UPS and switches to bypass mode.

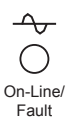
## Light Emitting Diodes (LED)

The following table describes the various LED behaviors and the system indications they provide.

LED	Behavior	Significance/Meaning
 On-Line/ Fault	Lights in green (Run)	Normal UPS (inverter) in operation
	Flashes in green	UPS output off
	Lights in red	UPS failure (no output)
	LED OFF (Stop)	Bypass operation on (inverter off)
 AC Input	Lights in green (Run)	Normal UPS input AC voltage
	Flashes in green	UPS input AC overvoltage
	LED off (Stop)	UPS input AC undervoltage (power failure)
 Alarm	Lights in amber	Warning
	Flashes in amber	Warning
	LED off (Stop)	Normal UPS (Inverter) in operation
 Timer	Lights in green	Schedule/timer setting
	Flashes in green	Execution notice of reserved operation (5 mins. in advance)
	LED off	No schedule/timer setting

## Display Screens

### Screen Arrangement

The display screens are organized into three groups that can be cyclically selectable by pressing the **SELECT** key. The groups are:

SCREEN ARRANGEMENT GROUPS		
1	System Overview Screens	Provides operational status summary
2	Data Display Screens	Provides detailed UPS data monitoring
3	Data Settings Screens	Provides system configuration

### System Overview Screens

The System Overview screens provide a summary of the current operational state of the UPS. Only one of the several possible overview screens is available at any moment. The current screen is automatically determined based upon the UPS state.

### UPS Start-Up Screens Sequence

The Start-Up screens consist of a series of automatically sequencing System Overview screens. These screens notify operator of steps taken by UPS during its initialization. The sequence of Start-Up screens begins when AC input power is detected at UPS input.

If the correct AC input power is available and no abnormal operating conditions are present then the following system message will be displayed on the LCD screen.

**TOSHIBA 1600 UPS  
INITIALIZING...**

Next, the LCD will report the current date and time. If necessary, the proper date and time can be set from the Data Settings screens (see pages 33 and 36 for details). The date and time appear using the format depicted in the following example:

**05/09/2007 (WED)  
15.:22:47**

Next, the LCD will report the current UPS Operational Mode and the current percentage of the maximum UPS capacity being supplied. Initially, the UPS is in bypass mode, and the following screen will appear:

**BYPASS OPERATION  
LOAD ###%**

**NOTE: If input voltage is removed while UPS is in the Bypass Mode the output stops.**

Only if the UPS is instructed to enter its online (normal) mode, will the UPS attempt transfer into such operation mode. To enter the normal mode, the **RUN** key is pressed or the **AUTO RUN** has been configured to **YES** (AUTO RUN setup is described in the Data Screen Settings actions on pages 33 - 38. If either condition exists, the following screen will appear:

**UPS OPERATION**  
**LOAD ###%**

Shortly after transfer into the UPS online (normal) mode, the UPS will automatically begin a battery test if the setting is enabled (see page 35). This test ensures a healthy battery system is available should it be necessary to support the load. During the test, the LCD reports the current battery voltage as a percent of its expected value at full charge. This figure will drop throughout the test, as the battery voltage is intentionally lowered to test performance. The test lasts for about 10 seconds, during which the following screen appears:

**BATTERY TEST**  
**BAT VOLTAGE ###%**

Once the battery test has concluded, the LCD will return to display of the current UPS operation mode and percent load. It should appear as follows:

**UPS OPERATION**  
**LOAD ###%**

## Data Display Screens

The Data Display screens sequentially display the data parameters that can be monitored by operator. To enter the series of Data Display screens, press **UP** or **DOWN** arrows while the current System Overview Screen is appearing.

### NOTES

1. If the **SET/MONITOR** key is pressed from any of the Data Display screens then the display will advance to the Data Setting screens. See page 33.
2. Displays 240V output voltage.
3. Displays the current as a % of maximum load capacity.
4. Displays the battery charge voltage as a % of the rated nominal DC voltage of the batteries.
5. Displays the date and time setting.
6. If the **SHIFT/SELECT** key is pressed from any one of the Timer Start Data, Timer Stop Data, Weekly Schedule, Special Operate, and Special Off time screens then special Data Display screens are viewed. These functions can only to be changed via the serial communication interface (see page 32).

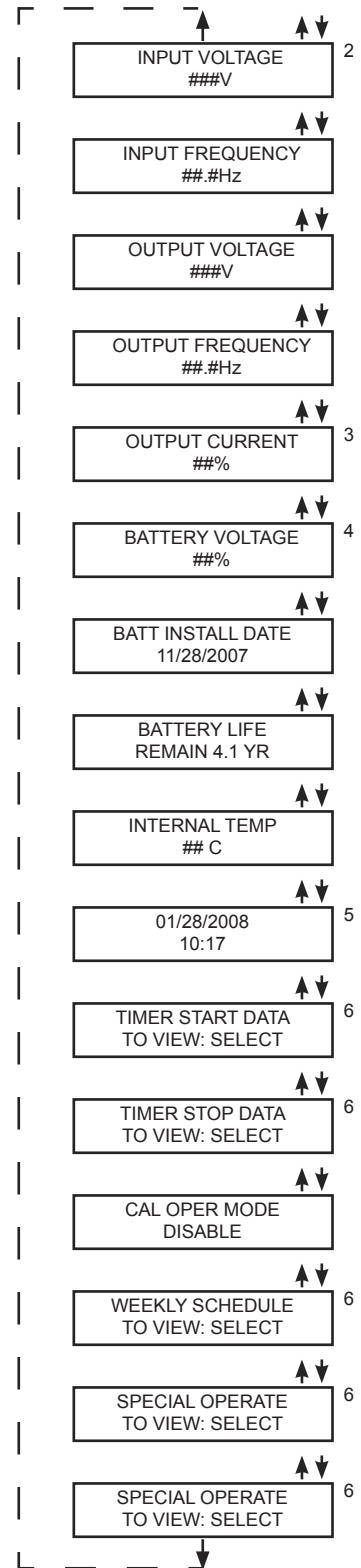

## Special Display Screens

The special Data Display screens show below depict settings that can be viewed (but not changed locally) on the LCD panel. These settings can only be changed through the RS232C or optional RemotEye network card.

Continued from Timer Start Data screen page 31	START TIME 1 DAY ##HR ##MIN ##SEC
Continued from Timer Stop Data screen page 31	STOP TIME 1 DAY ##HR ##MIN ##SEC
Continued from Weekly Schedule Data screen page 31	WEEKLY (MON) ###.## - ###.##
Continued from Special Operate Data screen page 31	START 1 ###.## - ###.##
Continued from Special Off Time Data screen page 31	STOP 1 ###.## - ###.##

### NOTES

1. To access the data setting screens press the **SET/MONITOR** key from any of the (see page 33) Data Settings screens.
2. Pressing the **SHIFT/SELECT** and **CANCEL** key returns to the Data Display screens.

### Data Setting Screens

The 'Data Setting screens' sequentially display the data variables that can be set. Each variable is displayed as the **DOWN** arrow key is pressed. The **UP** arrow can also be pressed at any time to back up to the previous screen:

#### NOTES

1. When the automatic battery test mode has been set to **YES** then the this screen is displayed when scrolling through the Data Setting screens.

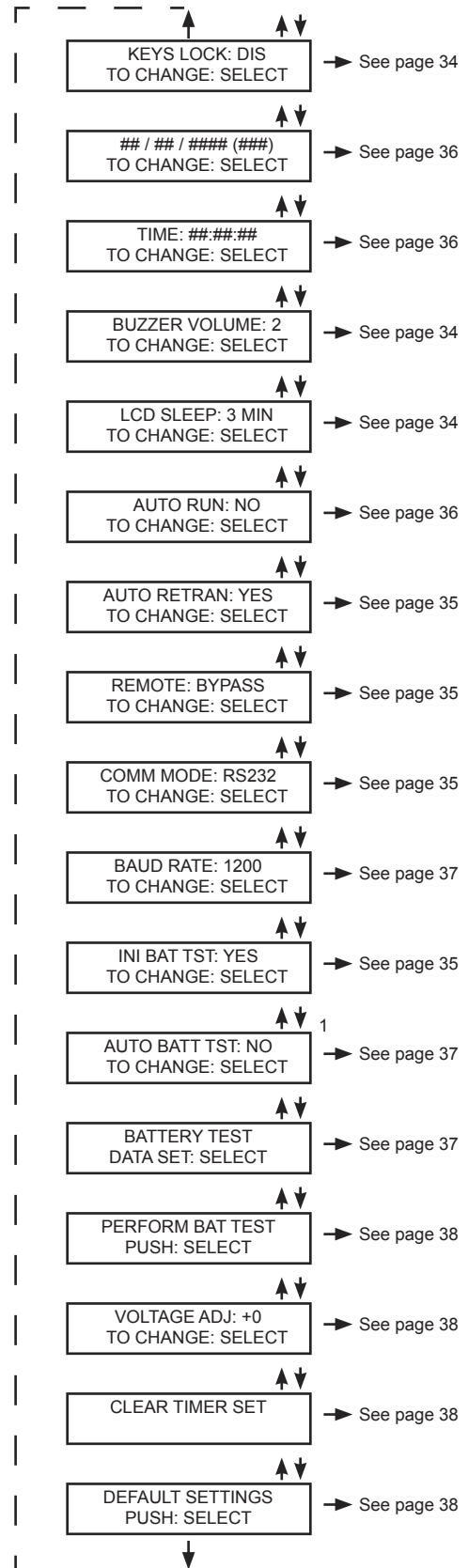
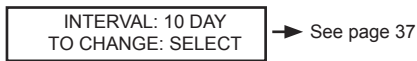

### Data Setting Screens (Cont'd)

The following screens show the procedure for setting the data variables. They are accessed from the main Data Setting screens (see page 33) when the **SHIFT/SELECT** key is pressed:

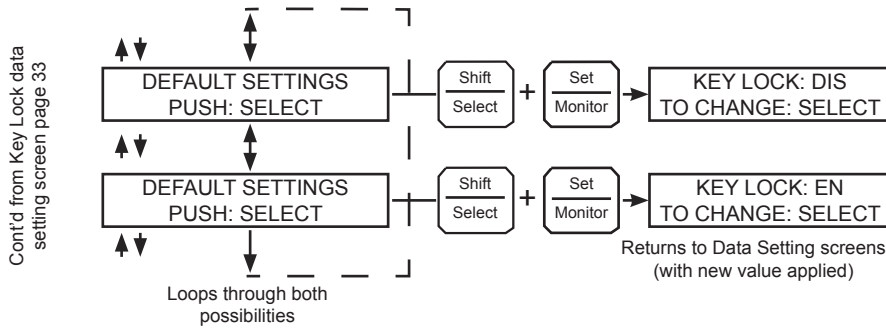

**Key Lock function:** Allows the operator to disable the **RUN + STOP** button functions. When this function is set to **EN** the unit will remain in the operating mode it was in when enabled and will not be able to be changed with the **RUN + STOP** buttons until this function is disabled. With this function set to **DIS**, the **RUN + STOP** buttons function normally.

Default setting is **DIS**.

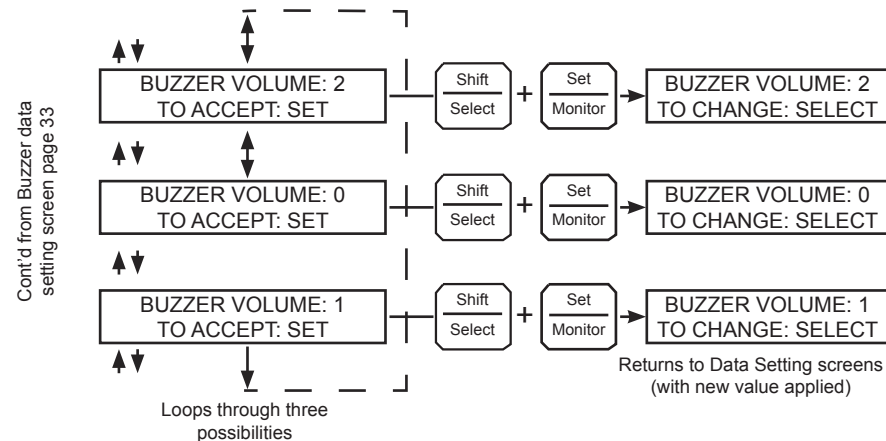

**Buzzer:**  
2 = High  
1 = Low  
0 = Off

Default setting is 2 = High (loudest)

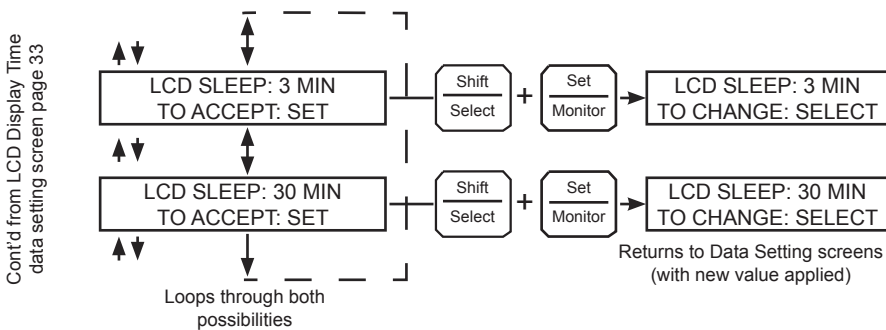

**LCD Sleep:** Displays the number of minutes (3 or 30) of idle time before the LCD will go blank (this is to prolong LCD life). The LCD will be active again once a display button is pressed.

Default setting is 3 MIN.

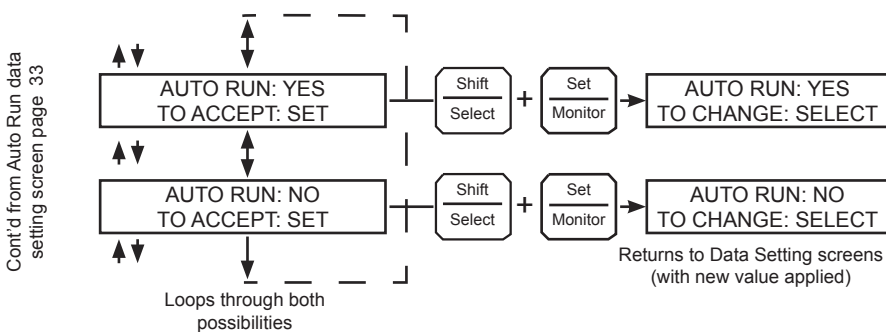

**Auto Run:** If set to **YES**, the unit will automatically start up in the UPS mode (on line) when input voltage is applied, regardless of what mode it was in when shut down.

Default setting is **NO**.

## Data Setting Screens (Cont'd)

The following screens show the setting procedure for setting the data variables. They are accessed from the main 'Data Setting screens' (see page 33) when the **SHIFT/SELECT** key is pressed:

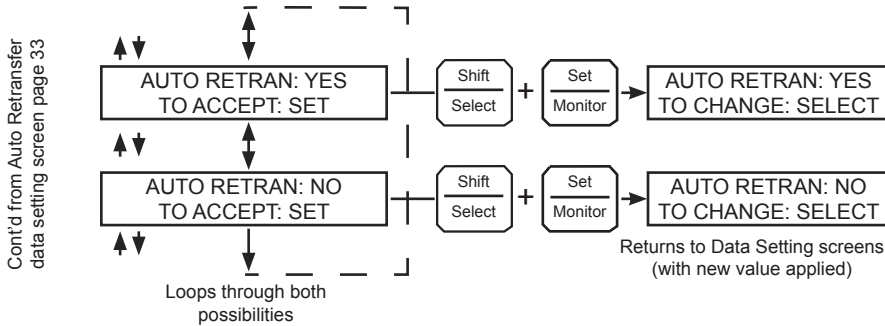

Set to YES, the unit will automatically retransfer back to UPS mode after transferring momentarily to bypass mode to prevent a sag in the output due to an instantaneous load change. If set to NO, the unit will attempt to ride out the load change and the output voltage could be decreased momentarily.

Default setting is YES.

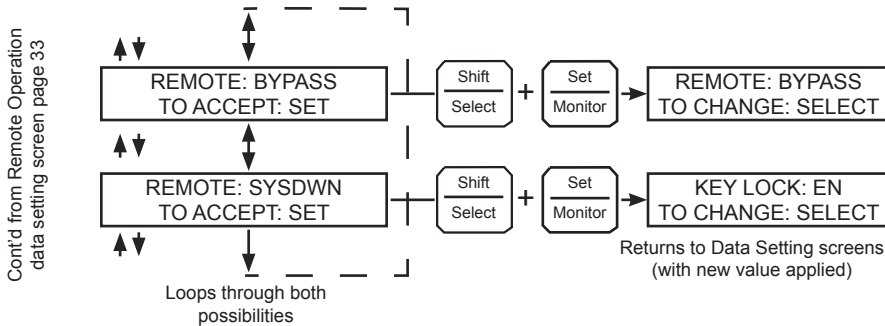

This setting uses the remote switch to place the unit in bypass mode.

This setting uses the remote switch to shut the output of the unit off. While off, the On-Line LED will be flashing and the LCD will display the message:

OUTPUT SHUTDOWN  
REMOTE OFF

The remote switch connection is on the rear terminal block at terminals 16 and 17. The unit will transfer 2 seconds after the switch opens.

Default setting is BYPASS.

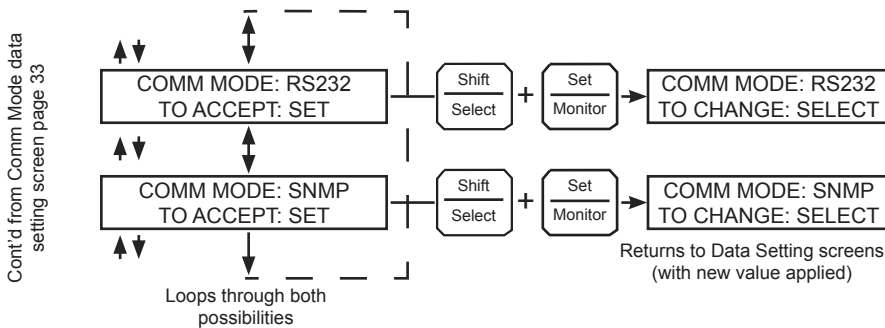

This setting selects the RS232 as the communication port. SNMP is disabled.

This setting selects the SNMP as the communication port. RS232 is disabled.

Default setting is SNMP.

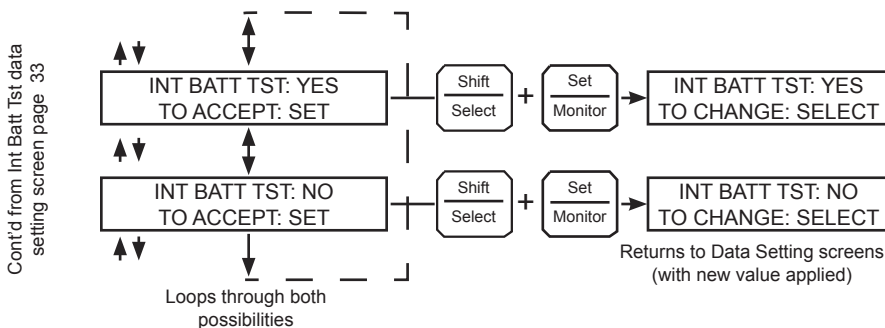

Set to YES, the unit will perform a battery test the first time the unit transfers to On-Line. If Auto Run (see page 34) is set to YES then the battery test will be done at power up.

Default setting is NO.

### Data Setting Screens (Cont'd)

The following screens show the procedure for setting the data variables. They are accessed from the main Data Setting screens (see page 33) when the **SHIFT/SELECT** key is pressed:

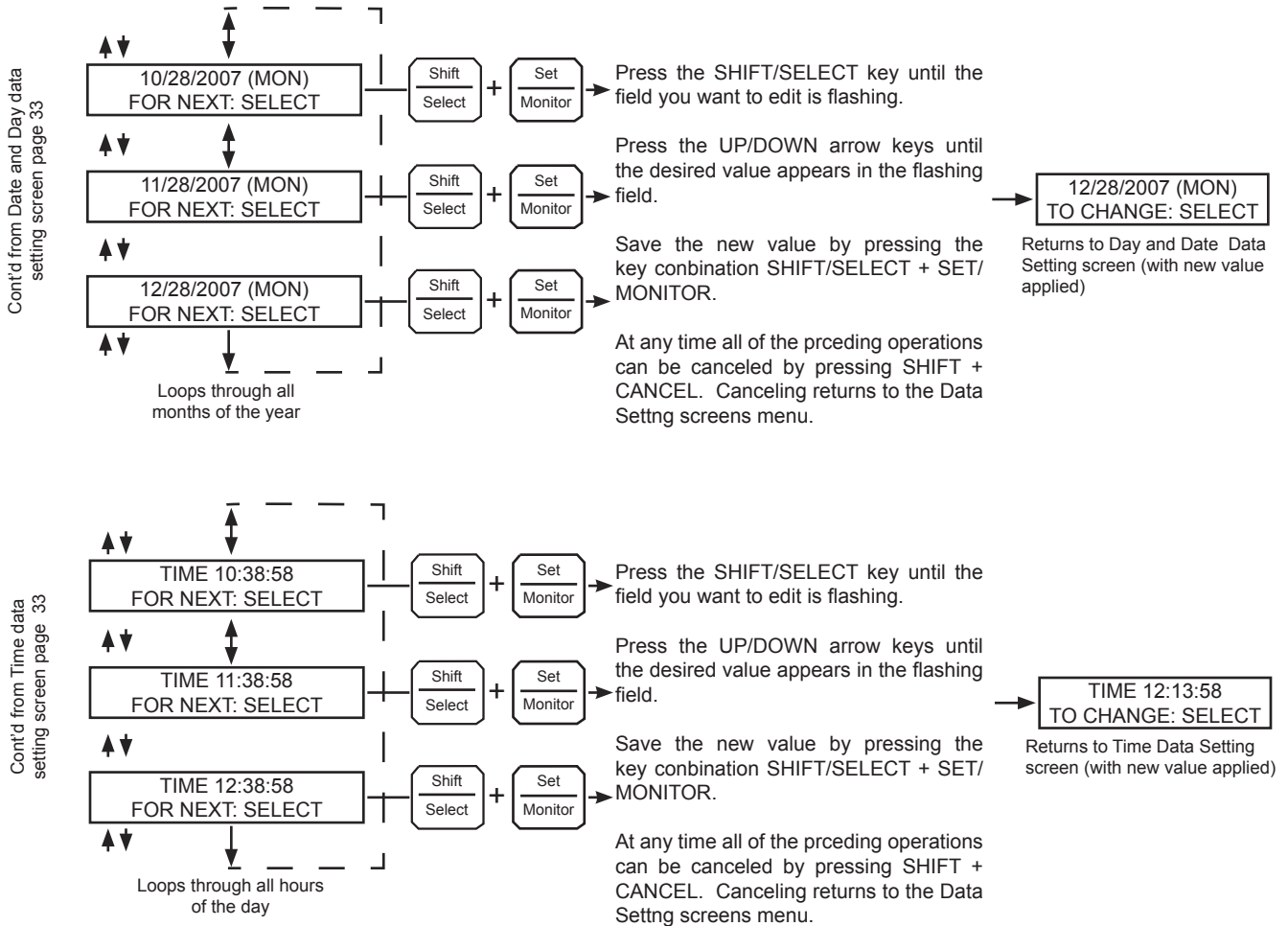

### Data Setting Screens (Cont'd)

The following screens show the procedure for setting the data variables. They are accessed from the main Data Setting screens (see page 33) when the **SHIFT/SELECT** key is pressed:

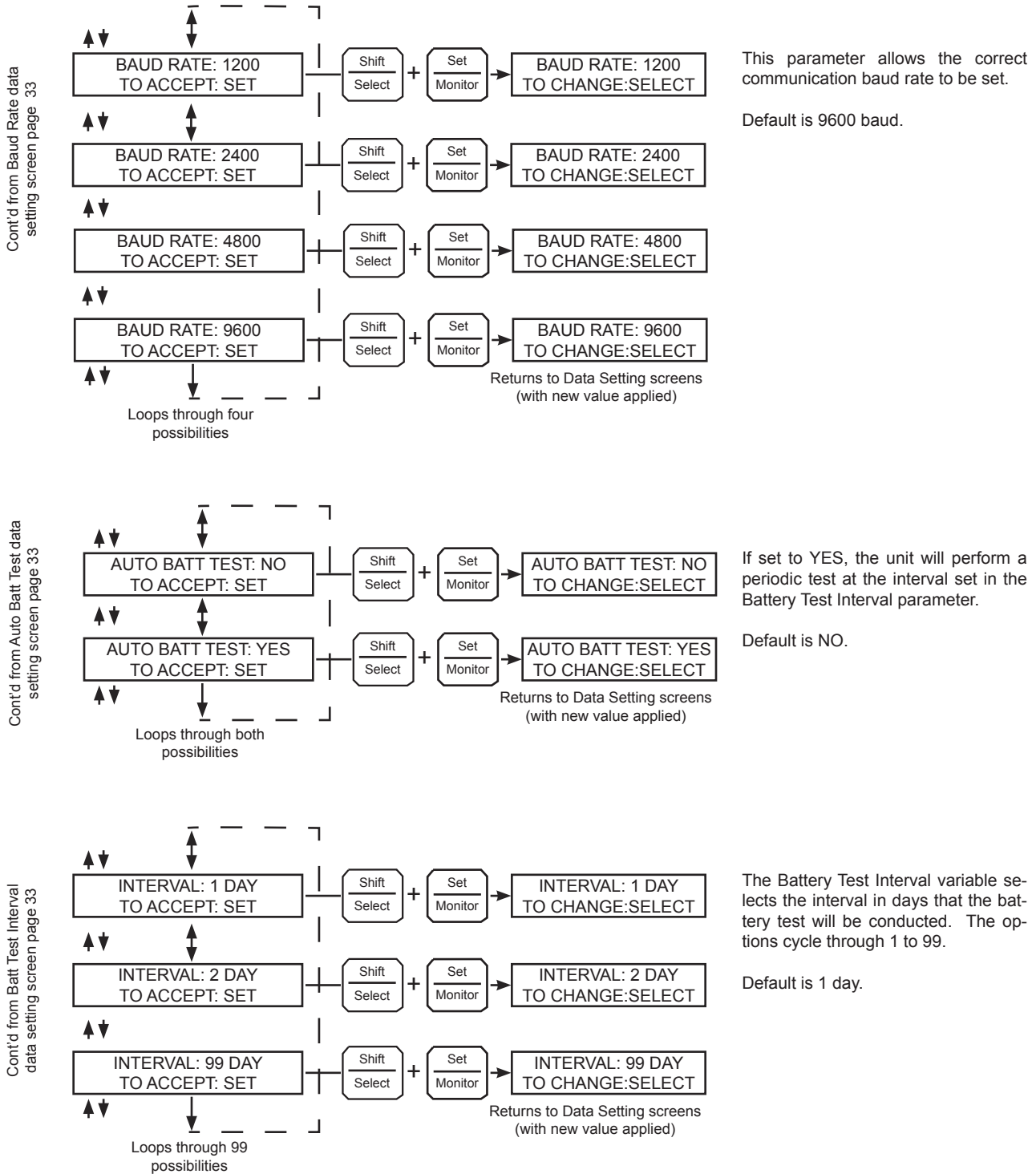

## Data Setting Screens (Cont'd)

The following screens show the setting procedure for setting the data variables. They are accessed from the main Data Setting screens (see page 33) when the **SHIFT/SELECT** key is pressed:

Cont'd from Bat Test Interval data setting screen page 33

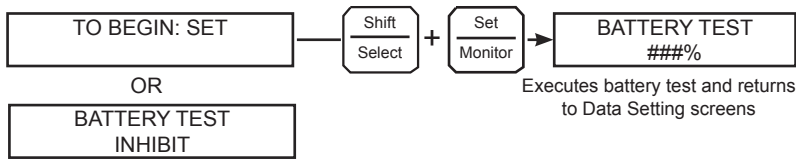

This parameter has no options to set. A battery test will be performed once the SHIFT + SET button is pressed.

If the BAT TEST INHIBIT message is displayed, it indicates that a battery test has been performed recently. The UPS will not allow frequent battery tests to insure that the batteries remain in a fully charged state.

Cont'd from Buzzer data setting screen page 33

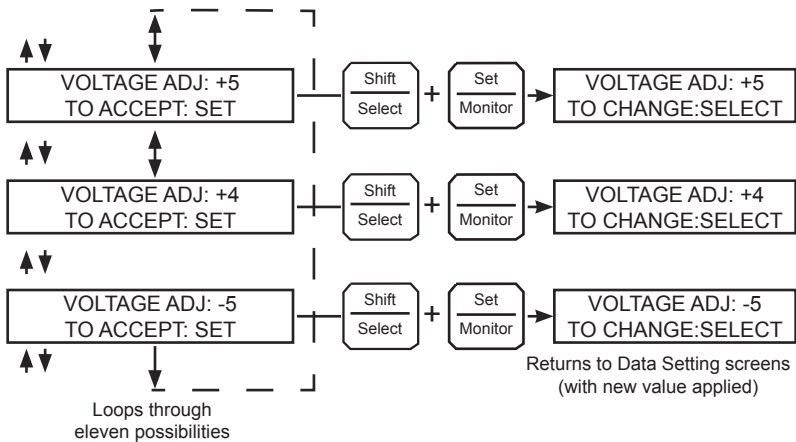

This parameter allows the user to offset the output voltage (while the unit is running on-line) in 1% increments over a range of +/-5% total offset.

Default value is 0%

Cont'd from Clear Timer data setting screen page 33

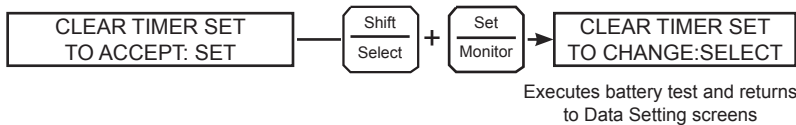

This parameter has no options to set. Pressing the SHIFT + SET button while this message is displayed will cancel timer settings.



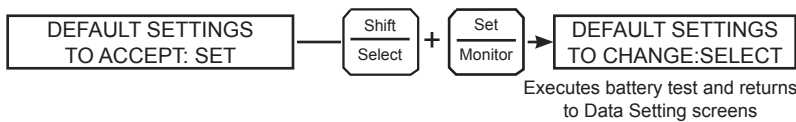











Cont'd from Clear Timer data setting screen page 33



This parameter has no options to set. Pressing the SHIFT + SET button while this message is displayed will reset all variables to their default value.

## System Warning Messages

Warning messages will be displayed when an abnormal operating condition occurs. The following chart shows possible messages and their meaning.

LCD Message	LED Message	Meaning/Action
OVERLOAD: 132%	  Alarm Amber LED Flashes	<b>Meaning:</b> The UPS is overloaded (110% or above). Unit will switch to bypass operation or shut down if no action is taken. <b>Action:</b> Shut down excess equipment to reduce load
OL: REDUCE LOAD	  Alarm Amber LED Flashes	<b>Meaning:</b> The UPS is overloaded (110% or above) and has switched to bypass. Unit will shut down the output if no action is taken. <b>Action:</b> Shut down excess equipment to reduce load
BATTERY LOW 90%	  Alarm Amber LED Flashes	<b>Meaning:</b> The battery level has dropped low (about 90% or less) during operation. Continued operation in this mode will deplete battery and cause output shut down. <b>Action:</b> Immediately shut down the load equipment in an orderly fashion and then press the <b>STOP</b> key.
UPS-TEMP 52°C	  Alarm Amber LED Flashes	<b>Meaning:</b> The unit is overheated (warning is given when the internal temperature reaches and exceeds 50° C rise @ 40° C ambient). <b>Action:</b> Check to see if the ambient temperature is abnormally high (40° C or more). If so, turn on air conditioning and check the ventilation fan at the back of the unit for operation or obstructions. Otherwise, shut down the unit and call for service.
REPLACE BAT SOON	  Alarm Amber LED Flashes	<b>Meaning:</b> Advance notice that batteries are nearing the end of the expected lifetime. <b>Action:</b> Contact your Toshiba authorized service center to arrange for battery replacement.
REPLACE BATTS	  Alarm Amber LED Flashes	<b>Meaning:</b> Batteries at end of life. <b>Action:</b> Have batteries replaced immediately.
REQUIRES SERVICE PLEASE SERVICE	  Alarm Amber LED Flashes	<b>Meaning:</b> Inspection of unit is advised. <b>Action:</b> Have inspection/service performed.















## System Fault Messages

When an abnormal operating condition occurs the following fault message will be displayed

FAULT (BYP OPER)  
OUT-0V DC-0V

If the input voltage is normal when the fault occurs then the UPS will switch immediately to the bypass mode to continuously feed power to the load. If the input power is abnormal while in the bypass mode the UPS will shut down the output to prevent load equipment damage.

Press **CANCEL** or **RESET** keys to view the messages explaining the system fault.

LCD Message	LED Message	Meaning/Action
DC-OC	  Red LED On-Line/ Fault Flashes	<b>Meaning:</b> DC overcurrent condition occurred. <b>Action:</b> UPS is probably faulty. Check the UPS operating conditions at time of fault. Not advisable to try restarting. Call for service.
OUT-0V	  Red LED On-Line/ Fault Flashes	<b>Meaning:</b> Output overvoltage condition occurred. <b>Action:</b> UPS is probably faulty. Check the UPS operating conditions at time of fault. Not advisable to try restarting. Call for service.
OUT-UV	  Red LED On-Line/ Fault Flashes	<b>Meaning:</b> Output undervoltage condition occurred. <b>Action:</b> UPS is probably faulty. Check the UPS operating conditions at time of fault. Not advisable to try restarting. Call for service.
DC-0V	  Red LED On-Line/ Fault Flashes	<b>Meaning:</b> DC overvoltage condition occurred. <b>Action:</b> UPS is possible faulty, input wiring error, input overvoltage or connection of a motor load. Try restarting. If condition persists call for service.
OVERLOAD	  Red LED On-Line/ Fault Flashes	<b>Meaning:</b> Output overload condition occurred. <b>Action:</b> Reduce equipment load to 100% or less and try restarting.
DC-UNBALANCE	  Red LED On-Line/ Fault Flashes	<b>Meaning:</b> DC voltage unbalance occurred. <b>Action:</b> Possible causes are UPS fault or connection of half-wave rectifier load. Check load and try restarting. If condition persists, call for service.
OVERHEAT	  Red LED On-Line/ Fault Flashes	<b>Meaning:</b> Overheating condition occurred. <b>Action:</b> Check unit for blocked or in-operable fan. Lower ambient temperature if it is 104 °F (40 °C) or greater. Bypass operation will also cease if overheat condition is not corrected within 1 hr. from inverter shutdown. Try restarting. If condition re-occurs plan for total shutdown and call for service.

### Status Change Indications

Warning messages will be displayed when an abnormal operating condition occurs. The following chart shows possible messages.

LCD Message	Meaning/Action
AUTO RETRANSFER	<p><b>Meaning:</b> The UPS has automatically entered the bypass mode because it detected an output current that is larger than the inverter can normally handle.</p> <p><b>Action:</b> Remove excess load equipment to reduce the output current.</p>
AUTO RETRANSFER	<p><b>Meaning:</b> The UPS input frequency is outside of the <math>\pm 1</math> Hz synchronization frequency tolerance of the inverter output frequency.</p> <p><b>Action:</b> No action is necessary. Unit cannot switch to bypass mode while the input frequency is out of tolerance with the output frequency.</p>
BATTERY LOW	<p><b>Meaning:</b> The battery level has dropped low (about 90% or less) during operation. Continued operation in this mode will deplete battery and cause output shut down.</p> <p><b>Action:</b> Immediately shutdown the load equipment in an orderly fashion and then press the <b>STOP</b> key.</p>
TIME TO RUN 4 MIN	<p><b>Meaning:</b> A start notice is displayed 5 minutes before starting the UPS when the start timer is set by communication, and continues to display remaining time during countdown.</p> <p><b>Action:</b> None required</p>
TIME TO STOP 10 SEC	<p><b>Meaning:</b> A stop notice is displayed 5 minutes before stopping the UPS when the stop timer is set by communication.</p> <p><b>Action:</b> None required.</p>
KEY LOCK: EN	<p><b>Meaning:</b> When the key lock is set or the timer is set to start/stop the UPS by data communication, pressing the <b>RUN</b> or <b>STOP</b> key displays this message.</p> <p><b>Action:</b> None required.</p>

## UPS Protection System

### System Protection Features

The following schematic shows the electrical locations of the protection devices on the UPS.

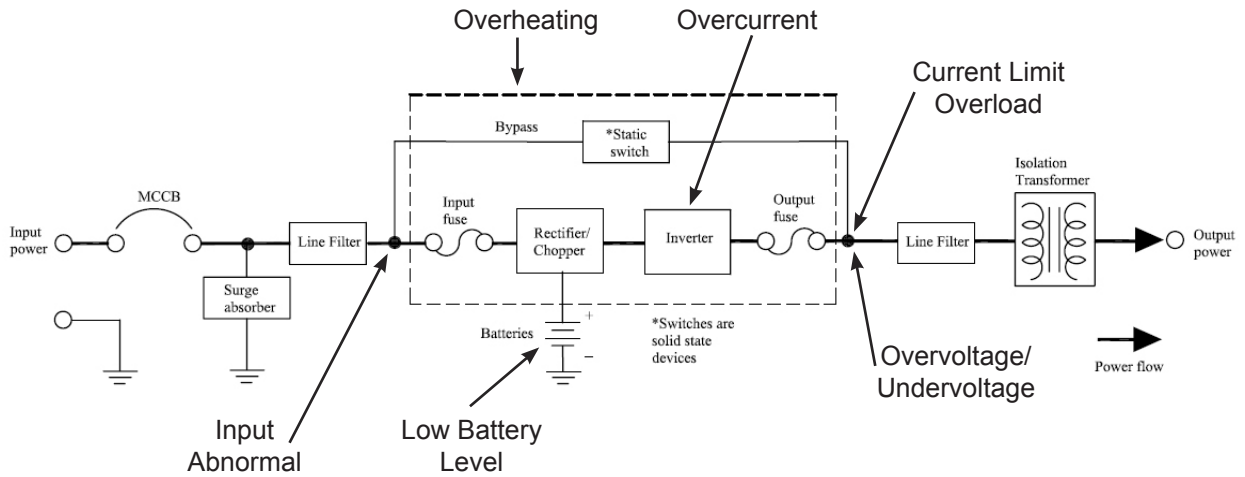

### System Protection Functions

The following charts show the built-in system fault protection functions on all the UPS models.

**BUILT-IN UPS FAULT PROTECTION FUNCTIONS**

Protection Item	Output Overvoltage	Output Undervoltage	Output Overload
LCD Message	<b>OUT-OV</b>	<b>OUT-UV</b>	<b>OVERLOAD</b>
Cause	Control malfunction; chip error	Control malfunction; Fuse opened; Load issue	Overload – Short circuit at load
Operation Mode After Fault	Bypass operation – Chopper and inverter are stopped		Inverter OL: Transfer to bypass; Bypass OL: Inverter, chopper stopped
Audible Alarm	Yes – Continuous buzzer		See Audible Alarm Functions on page 26
Visible Alarm	Red Fault LED on		Inverter OL: Fault lamp off Bypass OL: Fault lamp on
Relay Contact Alarm	Fault relay closed Bypass relay closed		Fault relay open; Inverter OL: Bypass relay closed Bypass OL: Bypass relay open
Auto-retransfer	No		Inverter OL: Yes if bypass is OK Bypass OL: No

**BUILT-IN UPS FAULT PROTECTION FUNCTIONS (CONT'D)**

Protection Item	Internal Overheat	DC Circuit Overvoltage	DC Circuit Overcurrent
LCD Message	<b>OVERHEAT</b>	<b>DC-OV</b>	<b>DC-OC</b>
Cause	Fan failure; High ambient temperature	Chopper malfunction	Inverter/chopper fault
Operation Mode After Fault	Shutdown – No output	Bypass operation – Chopper and inverter are stopped Inverter OL – Transfer to bypass	
Audible Alarm	Yes – Continuous buzzer		
Visible Alarm	Red Fault LED on		
Relay Contact Alarm	Fault relay closed Bypass relay closed		
Auto-retransfer	No		

## Preventive Maintenance/Parts Replacement

### Preventive Maintenance

Toshiba 1600EP Series of uninterruptible power systems have been designed to provide years of trouble-free operation requiring a minimum of preventive maintenance.

The best preventive measure that the UPS user can take is to keep the area around the unit, particularly the air inlet vents, clean and free of moisture and dust accumulations. If the atmosphere of the installation site is very dusty, use a vacuum cleaner to periodically remove dust accumulations around and from the unit.

CAUTION

**Only a qualified Toshiba representative should be allowed to perform any routine maintenance or service on this equipment other than those preventive maintenance details which are described directly above this caution.**

### Parts Replacement

The following list shows recommended intervals for periodic replacement of certain UPS parts:

1. Aluminum electrolytic capacitors: Replace once every 5 years.
2. Fuses: Replace once every 7 years.
3. Cooling fan: When operated in an ambient temperature of 86 °F (30 °C) to 104 °F (40 °C), replace every 3.5 years. When operated in an ambient temperature of less than 86 °F (30 °C), replace every 5 years.
4. Batteries: In order to maintain system reliability, the UPS batteries should be replaced on a regular schedule. To ensure reliable operation, all of the batteries should be replaced at the same time. Use the following chart for replacement:

**UPS BATTERY REPLACEMENT**

BATT AMB TEMP	AVERAGE LIFETIME	(% REDUCED)
68 – 77 °F (20 – 25 °C)	Approximately 5 yrs.	0%
86 °F (30 °C)	Approximately 3.5 yrs.	30%
95 °F (35 °C)	Approximately 2.5 yrs.	50%
104 °F (40 °C)	Approximately 1.8 yrs.	66%
113 °F (45 °C)	Approximately 1.25 yrs.	75%

## Optional Receptacle Panel Installation Instructions

These are the instructions for installing the optional Modular Output Receptacle Panels for the 1600EP Series UPS. These instructions apply to all UE3-RP-XX panel options.

**WARNING:** The work outlined in these instructions is to be performed only on a completely un-energized UPS system.

Refer to Figure 1 for location of UPS referenced material. Refer to Figure 2 for material referring to the receptacle panel module.

Step 1: Remove the modular receptacle panel cover plate.

On the rear of the UPS, locate the cover plate for the receptacle panel module interface (see Figure 1).

Remove the 6 mounting screws.

Remove the cover plate. A square-shaped plug will appear exposed near the upper-left corner of the uncovered slot.

Step 2: Snap-In Output Receptacle modular panel

Carefully mate the square-shaped connector on the UPS to its matching counter part on the rear of the modular panel.

Step 3: Mount the receptacle panel

Attach the screws removed from the cover plate through the mounting holes of the receptacle panels and back into the UPS mounting points.

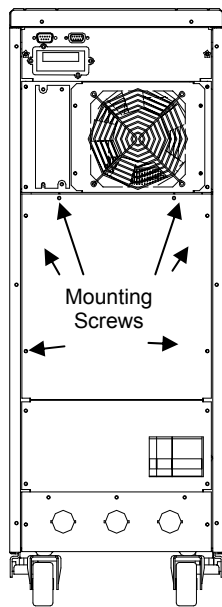

Figure 1

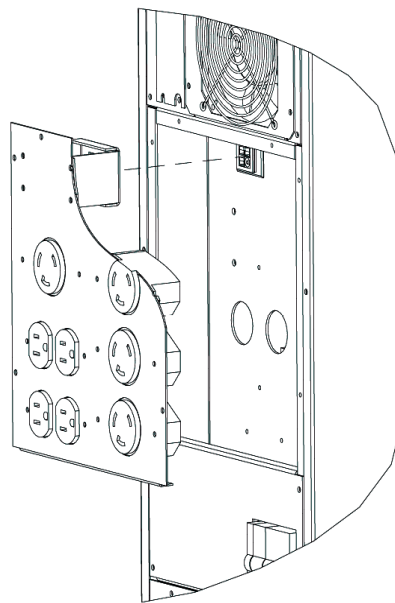



Figure 2

## Optional MB (Maintenance Bypass) Units

The following illustration shows the circuit power flow when the UPS is operating in the optional Maintenance Bypass Mode. The input on the UPS must be set for 240 VAC.

CAUTION

Ensure the UPS is in Static Bypass before switching the unit from UPS to Maintenance Bypass mode or from Maintenance Bypass to UPS mode. Failure to do so could result in damage to the maintenance bypass switch or the UPS.

---

This Maintenance Bypass unit can only be used for 240 V applications. Ensure the UPS voltage selector jumper is set to 240 V. See page 11 for the correct 240 V setting.

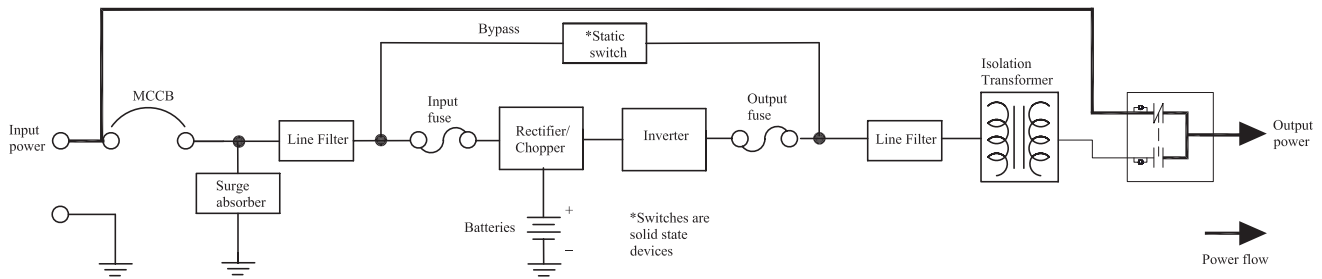

**POWER FLOW IN MAINTENANCE BYPASS MODE FOR ALL MODELS**

Follow the instructions below when switching to and from the Maintenance Bypass mode.

### From Inverter Mode to Maintenance Bypass Mode

1. Turn the RUN/STOP switch to the STOP position on the UPS.
2. Turn the Maintenance Bypass Switch to the Bypass position. The Bypass LED should be ON and the UPS LED should be OFF. The LEDs are next to the Maintenance Bypass switch, on the back of the UPS.
3. Turn the MCCB input breaker on the UPS to the OFF position. The UPS is now operating in Maintenance Bypass Mode.

### From Maintenance Bypass Mode to Inverter Mode

1. Turn the MCCB input breaker on the UPS to the ON position.
2. Turn the Maintenance Bypass switch to the UPS position. The UPS LED should be ON and the Bypass LED OFF
3. Turn the RUN/STOOP switch to the RUN position on the UPS. The UPS is now operating in the UPS Mode.

The following connections must be made to the Utility Panel and the Load Panel. The Main UPS output is located on the terminal block on the back of the UPS. (TB-4(X1) and TB-7(X3) 240 VAC.)

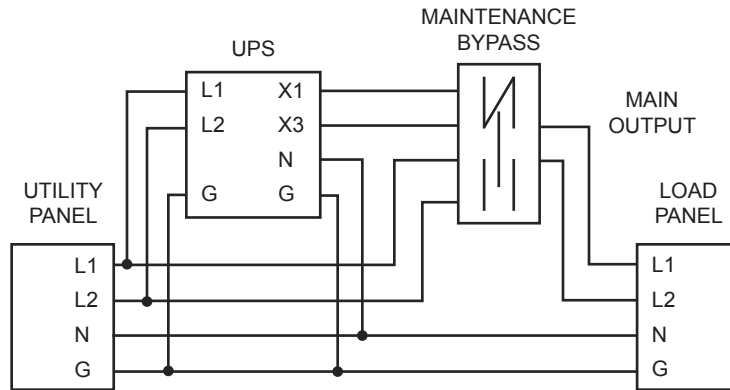

## External Layouts/Dimensions/Shipping Weights

### Dimensional Data

DIMENSIONAL DATA								
	3.6 kVA-RoHS	3.6 kVA	6 kVA	8 kVA	10 kVA	14 kVA	18 kVA	22 kVA
A	22.1 in. (561 mm)	27.5 in. (699 mm)	27.5 in. (699 mm)	28.4 in. (721 mm)	28.4 in. (721 mm)	39.1 in. (993 mm)	39.1 in. (993 mm)	39.1 in. (993 mm)
B	10 in. (254 mm)	10 in. (254 mm)	10 in. (254 mm)	13 in. (330 mm)	13 in. (330 mm)	17.5 in. (445 mm)	17.5 in. (445 mm)	17.5 in. (445 mm)
C	33 in. (838 mm)	33 in. (838 mm)	33 in. (838 mm)	33.5 in. (851 mm)	33.5 in. (851 mm)	34.8 in. (884 mm)	34.8 in. (884 mm)	34.8 in. (884 mm)
D	18 in. (457 mm)	24.7 in. (627 mm)	24.7 in. (627 mm)	25.7 in. (653 mm)	25.7 in. (653 mm)	35.6 in. (904 mm)	35.6 in. (904 mm)	35.6 in. (904 mm)
E	2.8 in. (72 mm)	2.8 in. (72 mm)	2.8 in. (72 mm)	2.7 in. (69 mm)	2.7 in. (69 mm)	3.47 in. (88 mm)	3.47 in. (88 mm)	3.47 in. (88 mm)

### Electrical Conduit Knock-out Data

ELECTRICAL CONDUIT KNOCK-OUT HOLE SIZES (DIAMETER)							
3.6 kVA-RoHS	3.6 kVA	6 kVA	8 kVA	10 kVA	14 kVA	18 kVA	22 kVA
6 ea. 1.125 in. (28.575 mm)	6 ea. 1.125 in. (28.575 mm)	6 ea. 1.125 in. (28.575 mm)	5 ea. 1.72 in. (43.69 mm)	5 ea. 1.72 in. (43.69 mm)	8 ea. 1.72 in. (43.69 mm)	8 ea. 1.72 in. (43.69 mm)	8 ea. 1.72 in. (43.69 mm)
–	–	–	1 ea. 1.5 in. (38.1 mm)	1 ea. 1.5 in. (38.1 mm)	–	–	–

### Unit and Shipping Weights

Model	Unit Weight		Shipping Weight	
	Pounds	Kilograms	Pounds	Kilograms
3.6 kVA-RoHS	280	127	325	147
3.6 kVA	322	146	371	168
6 kVA	346	157	395	179
8 kVA	476	216	533	242
10 kVA	476	216	533	242
14 kVA	784	356	835	379
18 kVA	784	356	835	379
22 kVA	784	356	835	379

External Layout for 3.6 kVA-RoHS, 3.6 kVA, and 6 kVA units.

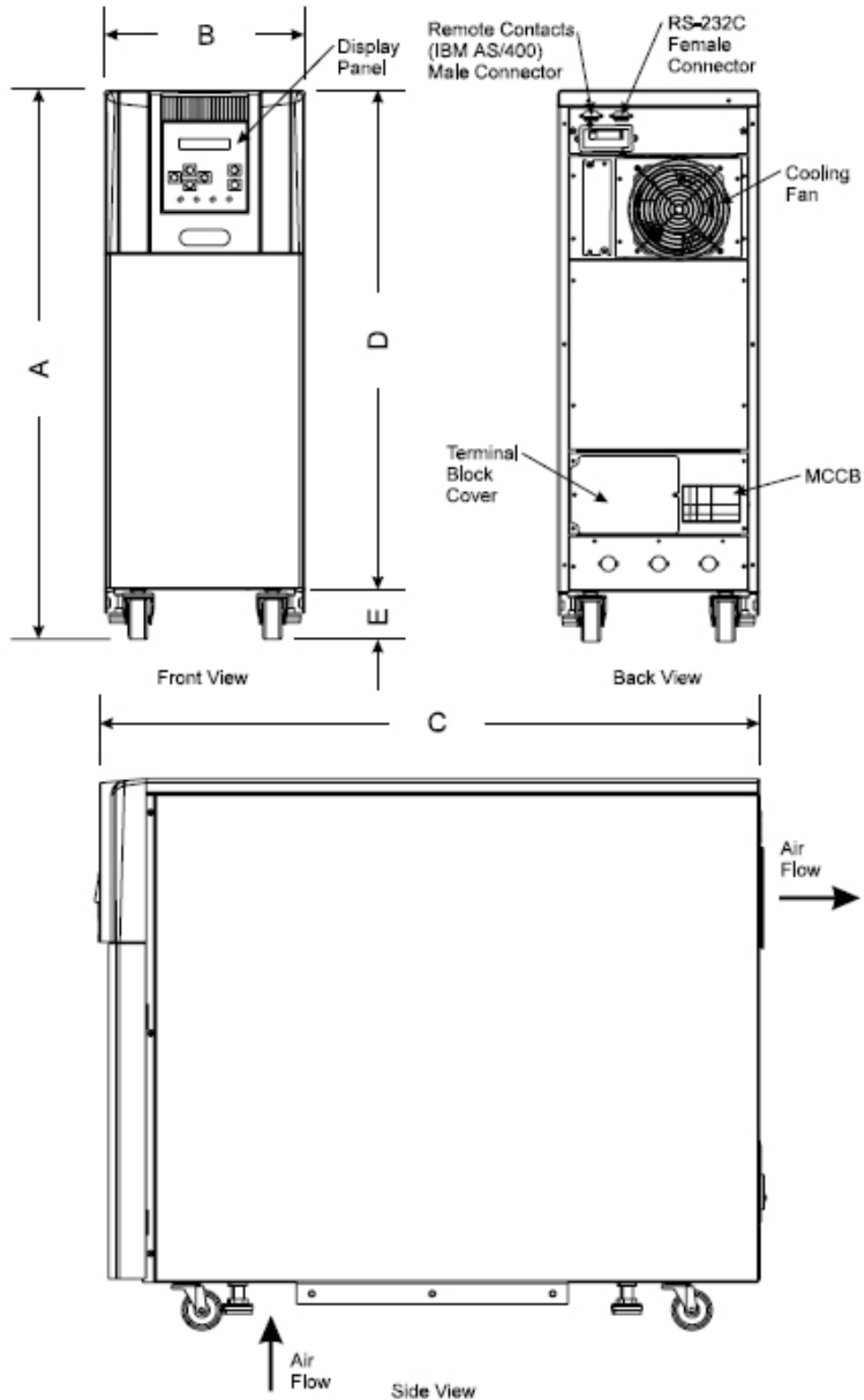

**External Layout for 8 kVA, 10 kVA, 14 kVA, 18 kVA, and 22 kVA units.**

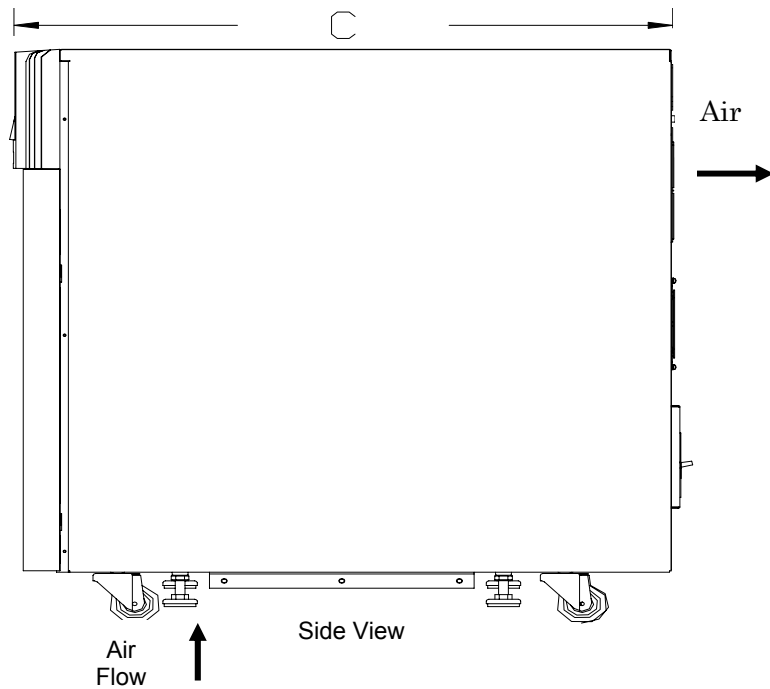
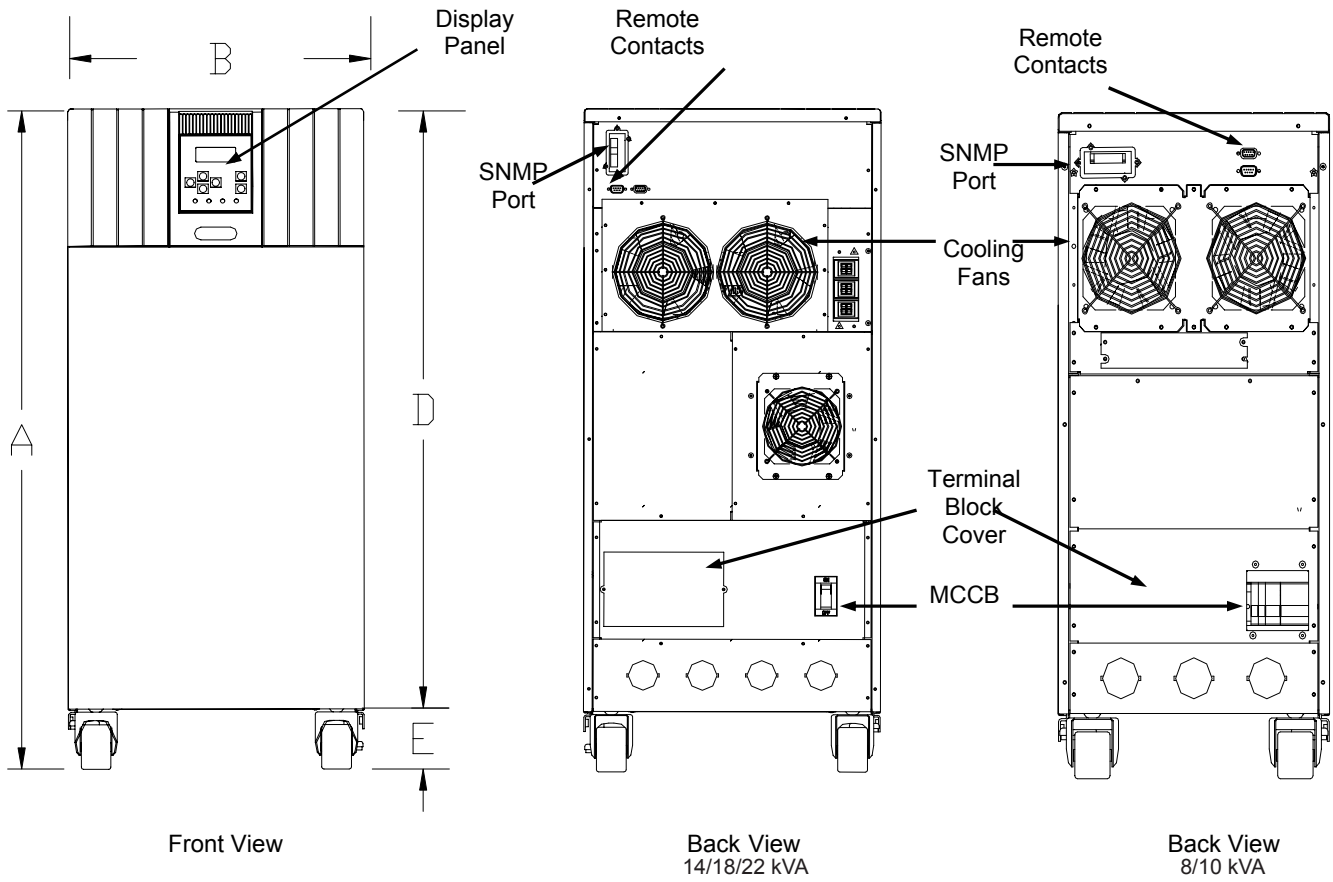

## Index

### A

- AC input mode 24
- Altitude 16, 19
- Application 5
- Audible alarm 5, 27, 42, 43
  - functions 26
- Automatic Retransfer 19

### B

- Backup mode 25
- Battery
  - backup mode 25, 26
  - backup time 15, 18, 21, 25
  - lifetime 19
  - low-voltage tolerances 21
  - manufacturer 20
  - pack 20
  - Pack (quantity) 20
  - recharge tolerances 23
  - recharging 23
  - replacement 3, 19, 39, 44
  - voltage drop 5, 12, 25
- Buzzer volume 19
- Bypass
  - disable 19
  - mode 22, 24, 28, 29
  - overload capacity 18
  - switch 19

### C

- capacitors 44
- Common-mode noise 5, 18
- Communication interface 12
- Conduit Knock-out, sizes 48
- Cooling fan 44

### D

- Data. *See* Data Display Screens, Data Setting Screens
- Data Display Screens 28, 29–32
- Data Setting Screens 28, 31, 33–38
- DB9 Connector
  - female pinouts 14
  - male pinouts 12
- Dimensional Data 48
- Disposal 6

### E

- Emergency Power Off (EPO) function 8, 11, 25, 29
- Enclosure 20
- Environment 6, 19
- Event Data Storage 19

### F

- fan 20, 39, 43
- Fault 19
  - protection functions 42, 43
  - signal 12, 24, 26
- Frequency

AUTO/MAN 18  
input 18  
output 18  
synchronization 41  
Warning 8, 41  
Front Panel layout 27

**G**

ground  
  Importance of, 7  
  RS-232C 14  
  terminals 11  
Grounding 7

**H**

Humidity 19  
humidity 6, 7

**I**

Input Capacity 18  
Input Frequency 18  
  warning 8, 41  
Input Voltage 15, 16, 17, 18, 19, 20  
  requirements 8  
Inspection 6, 39  
Installation Precautions 7  
Interface  
  communications 12, 13, 14  
  receptacle panel module 45  
  RS232 ASCII 19, 31  
  user 19  
Inverter Overload Capacity 18

**K**

Keys 19, 27, 28  
Knock-out, sizes 48

**L**

labels, warning 9  
LED (Light Emitting Diode) displays 27  
Lifetime  
  battery 19, 44  
  battery warning light 39  
  capacitors, Aluminum electrolytic 44  
  fan, cooling 44  
  fuses 44  
Liquid Crystal Display (LCD) Functions 27  
Low Voltage Tolerance 21

**M**

Maintenance Bypass, switching to and from 46  
Maintenance Bypass, voltage restrictions 46  
Maintenance Bypass Unit 46  
maximum ambient operating temperature 3  
Mode  
  AC Input 24  
  Battery Backup 25  
  display 27, 28, 29  
  Static Bypass 24  
  test 33  
monitoring. *See* Data Display Screens

**N**

Normal input power supply 12

## O

Operation modes. *See* Modes  
output disconnect 3  
Overload Capacity 18  
Overvoltage  
    DC 43  
    input 28  
    output 40, 42

## P

Peak Output Current 18  
Power Backup 5  
Power Conditioning 5  
Power factor  
    input 18  
    output, rated load 18, 21  
Power failure signal 12, 13  
Precautions 7, 8  
Preventive Maintenance 44  
Protection System 42

## R

Real Time Clock 19  
Receptacle Panels 45  
Recharge Time 18, 23  
relay switch 12  
remote contacts interface 12  
Remote Switch 11  
RemotEye Network Card 14  
Restrictions on UPS use 8  
RS-232C 14

## S

Safety instructions 1, 3  
Schedule Operation 19  
Shipping Weight 48  
Shutdown voltage 21  
Signal Function  
    RS-232C 12  
Signal Words 2  
Size  
    battery packs 20  
    UPS dimensions 20  
    wire 11  
Specifications 15  
Start-Up Screens 29  
Starting the UPS 22  
Status Change Indications 41  
Stopping the UPS 22, 41  
Stop Signal Operation 13  
Storage 6, 19  
    temperature 19  
synchronization frequency tolerance 41  
System Fault Messages 40  
System Warning Messages 39

## T

Terminal Block 11  
Theory of operation 5  
torque, tightening 11

## U

Unpacking 6

## UPS

Discharge Process 21, 25

UPS Connections 11

UPS functional overview 5

UPS stop signal input 12, 13

## V

ventilation 7, 8

Voltage Transient 18

Volume, Buzzer. *See* Buzzer Volume

## W

warning labels 9

Warranty c, d, 6

Weights, shipping 48

Weights, UPS 48



# TOSHIBA

**TOSHIBA INTERNATIONAL CORPORATION**

**INDUSTRIAL DIVISION**

13131 West Little York Road, Houston, Texas 77041

Tel. (713) 466-0277 Fax. (713) 466-8773

US (800) 231-1412 Canada (800) 872-2192 Mexico 01/800/527-1204

[www.Toshiba.com/ind](http://www.Toshiba.com/ind)

Printed in the U.S.A.